

arc

8"

2 3/4"

axis

PRODUCT ORDERING CODES

product id	center optics	length/ft	lamp	lamp config.	finish	up light	down light	ballast	voltage	circuits	suspension	hanger	other	controls	custom
ARC PL		4	T5	2	A	0*	0*	E	120	I	CA36	C			
ARC pendant		3	1 one lamp			0		E electronic		I one circuit		C cable		DS daylight sensor	
+W wall		4	2 two lamps			1		ERS rapid start		2 two circuits		+SM seismic		OS occ. sensor	
+A asymmetric		6	3 three lamps (T5/T5HO only)			2		D dimming (specify details)		+E em. circuit				DOS daylight / occ. sensor	
		8													
		12													
SB white solid baffle	S# system		T8	A	aluminum	0			120	CA# cable (36" std)	D dust cover			C custom description	
PL spec. para. louver			T5	W	white	1			277	CT# cable / t-bar stem (18" std)	B# batt. pack (quan./ lumens)				
ES elliptical slots			T5HO	C	custom	2			347	SA# (length / inch)	F fuse (one per ballast)				
F frosted diffuser						HP									
P perf						FP									
B blank						BK									

*Please refer to **il.3** Light Distribution Guide for up / down light reflector specifications. For use with **SB** or **PL** center optics only.

HANGER CONFIGURATIONS

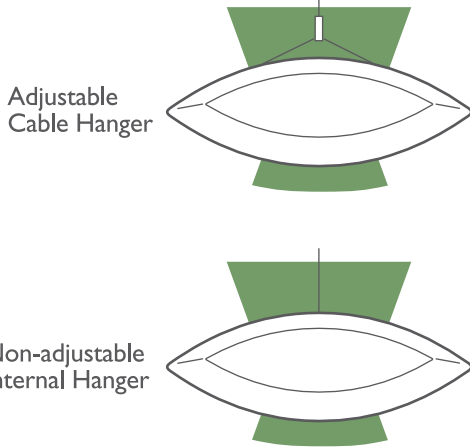

LAMP CONFIGURATIONS

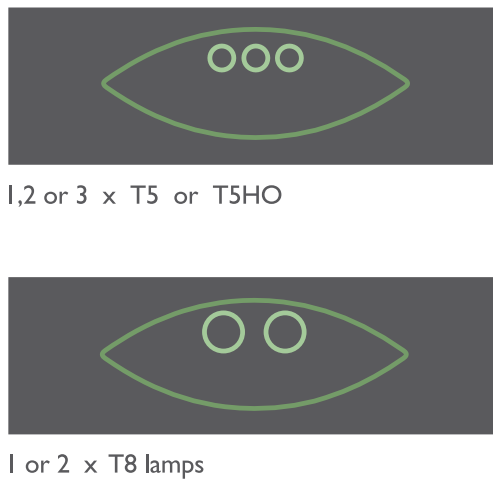

INTEGRATED CONTROLS

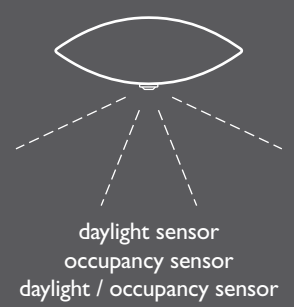

PHOTOMETRICS

Site specific lighting calculations and electronic photometric data are available from Axis Lighting

ARC Candlepower Distribution

Photopia Electronic Simulation
Test Lamps: 1 x F32T8 Fluorescent
ARC-PL-4-T8-1 direct / indirect
w/ MIRO Interior Reflectors Efficiency : 89%
To order - specify MIRO in 'custom' field of order code

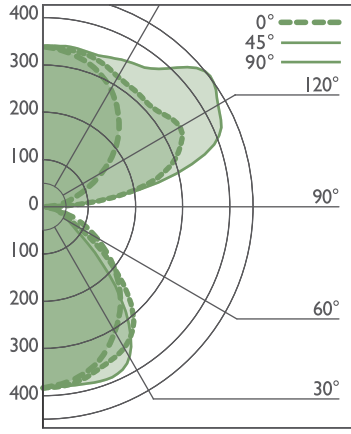

Photopia Electronic Simulation
Test Lamps: 2 x F32T8 Fluorescent
ARC-PL-4-T8-2 indirect/direct
w/ MIRO Interior Reflectors Efficiency : 85%

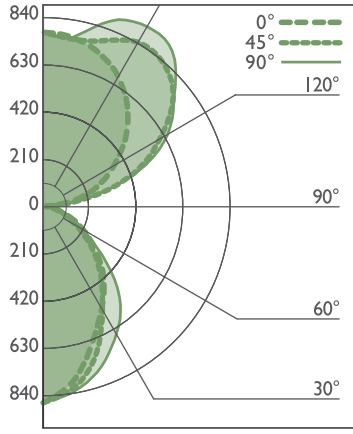

Illuminance (Footcandles)

Sample Typicals
Code: 2 x ARC-PB-24-T8-2 Reflectances:
(2x 24' curved w/ perf. baffles) Ceiling 80%
Test Lamps: 2 x F32T8 Walls 50%
Light Loss Factor: 0.8 Floor: 20%

Sample Room Layout
30' x 30' x 9' with work plane @ 2.5' AFF

20	21	26	32	35	34	31	28	31	34	35	32	26	21	20
20	23	31	42	50	45	37	32	37	45	50	42	31	23	20
22	26	38	55	67	58	45	38	45	58	67	55	38	26	22
23	28	43	62	75	66	51	43	51	66	75	62	43	28	23
24	30	45	66	81	70	54	46	54	70	81	66	45	30	24
25	31	47	68	83	72	56	48	56	72	83	68	47	31	25
26	32	48	70	85	74	58	50	58	74	85	70	48	32	26
25	32	48	69	83	74	58	49	58	74	83	69	48	32	25
26	32	48	70	85	74	58	50	58	74	85	70	48	32	26
25	31	47	68	83	72	56	48	56	72	83	68	47	31	25
24	30	45	66	81	70	54	46	54	70	81	66	45	30	24
23	28	43	62	75	66	51	43	51	66	75	62	43	28	23
22	26	38	55	67	58	45	38	45	58	67	55	38	26	22
20	23	31	42	50	45	37	32	37	45	50	42	31	23	20
20	21	26	32	35	33	30	28	30	33	35	32	26	21	20



PENDANT SPECIFICATIONS

arc

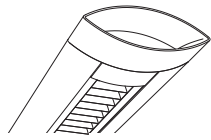

LOUVERS/BAFFLES
(65% uplight/35% downlight
with no up/down light reflectors*)

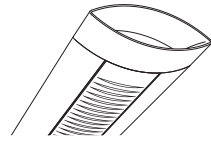

ELLIPTICAL SLOTS
(80% uplight/20% downlight)

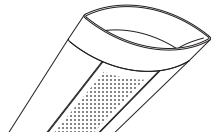

PERFORATIONS
(95% uplight/5% downlight)

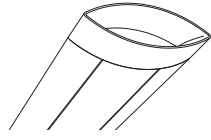

BLANK
(100% uplight/no downlight)

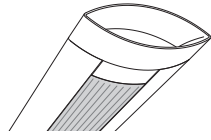

FROSTED DIFFUSER
(70% uplight/30% downlight)

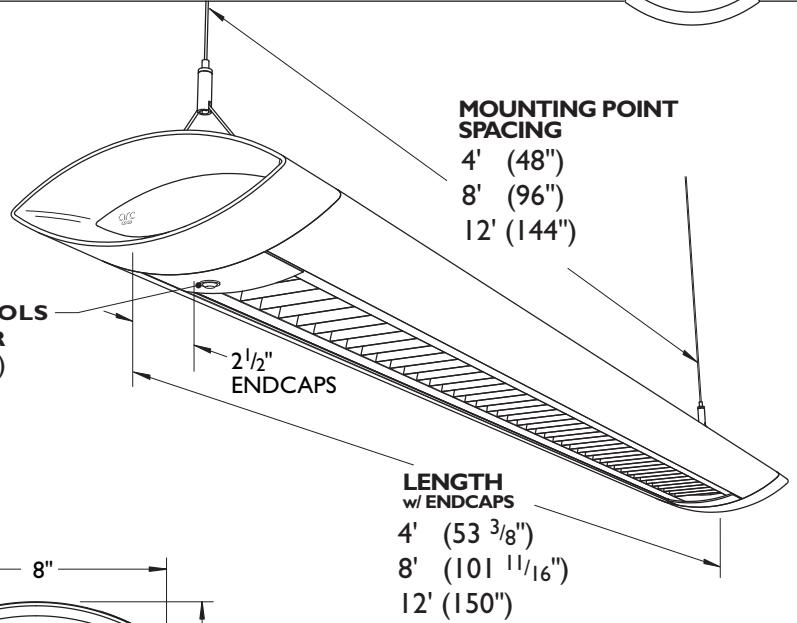

CONTROLS SENSOR
(optional)

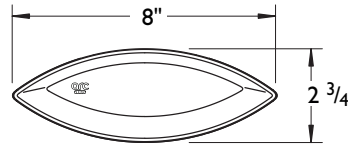

INSTALLATION PAGES

i 1.1 1.3 2.5

CONFIGURATIONS

HANGER

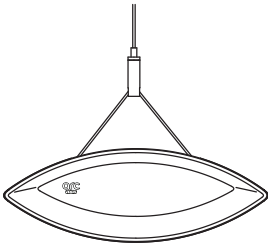

sliding cable hanger

LAMPS

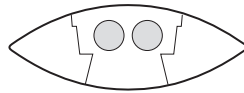

1 or 2 x T8 lamps

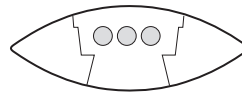

1, 2 or 3 x T5 or T5HO

REFLECTORS

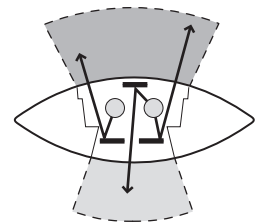

* Refer to page **i1.3** - "Light Distribution Guide" for customizing uplight/downlight ratios with variable reflectors

CONSTRUCTION

End Cap	Die Cast Zinc (0.060" nominal)
Side Profile	Extruded Aluminum (0.080" nominal)
Louvers	Die Formed Semi-Specular aluminum (22 gauge)
Baffles	Die Formed Aluminum (22 gauge)
Interior Brackets	Die Formed Sheet Steel (18 gauge)
Hanger	Aircraft Cable
Suspension	Aircraft Cable or Ø 5/8" Stem
Cable Grips	Quick Connecting / Release

Finish	Anodized, Powder Coated, Lacquered
Certification	UL listed to U.S. & Canadian standards

ELECTRICAL

Ballast Options	Electronic, Dimmable, Emergency
Emergency	Emergency Battery Pack or Circuit
Lamp Options	T8, T5, T5-HO
Voltage	120, 277, 347

PRODUCT ORDERING CODE

product id	optics	length / ft	lamp	lamp config.	finish	up light	down light	ballast	voltage	circuits	suspension	hanger	other	controls	custom	
ARC	PL	4	T5	2	A	0*	0*	E	120	1	CA36					
ARC	pendant	3 4 6 8 12	1 2 3	one lamp two lamps three lamps (T5 / T5HO only)	A W C	0 1 2	E ERS D	electronic rapid start dimming (specify details)	120 277 347	1 2 +E	one circuit two circuits em. circuit	C + SM	cable (36" std) cable / t-bar stem (18" std) (length / inch)	DS OS DOS	daylight sensor occ. sensor daylight / occ. sensor	
SB	white solid baffle	S #	T8		A		0		120	CA #	cable (36" std)	D	dust cover			
PL	semi spec. para. louver		T5		W		1		277	CT #	cable / t-bar	B #	batt. pack		C	
ES	elliptical slots		T5HO		C		2		347	SA #	stem (18" std) (length / inch)	F	(quan./4' sections) fuse (one per ballast)		description	
F	frosted diffuser						FP									
P	perf						HP									
B	blank						BK									

sample
ordering options

WALL MOUNT SPECIFICATIONS

arc

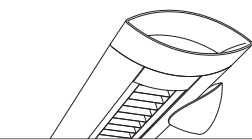

LOUVERS/BAFFLES
(65% uplight/35% downlight with no up/down light reflectors*)

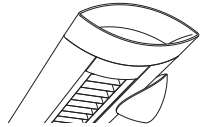

ELLIPTICAL SLOTS
(80% uplight/20% downlight)

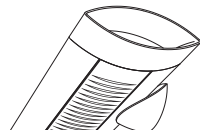

PERFORATIONS
(95% uplight/5% downlight)



BLANK
(100% uplight/no downlight)

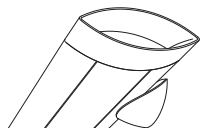

FROSTED DIFFUSER
(70% uplight/30% downlight)

2 1/2" ENDCAPS

CONTROLS SENSOR
(optional)

ELLIPTICAL SLOTS

LENGTH w/ ENDCAPS

4' (53 3/8")
8' (101 11/16")
12' (150")

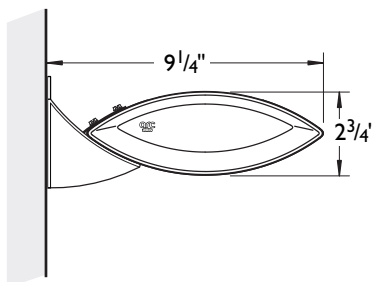

INSTALLATION PAGES

i 1.3 2.4

CONFIGURATIONS

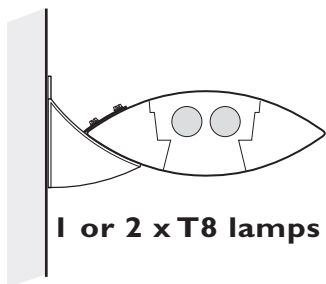

1 or 2 x T8 lamps

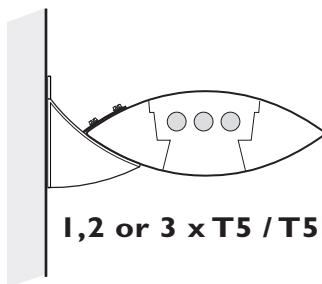

1, 2 or 3 x T5 / T5HO

REFLECTORS

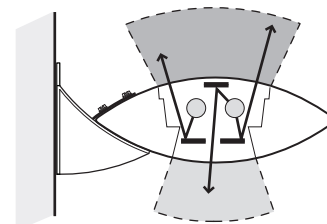

* Refer to page i1.3 - "Light Distribution Guide" for customizing uplight/downlight ratios with variable reflectors

CONSTRUCTION

End Cap	Die Cast Zinc (0.060" nominal)
Side Profile	Extruded Aluminum (0.080 " nominal)
Louvers	Die Formed Semi-Specular aluminum (22 gauge)
Baffles	Die Formed Aluminum (22 gauge)
Interior Brackets	Die Formed Sheet Steel (18 gauge)
Wall bracket	Die Cast Zinc (0.060" nominal)
Finish	Anodized, Powder Coated, Lacquered
Certification	UL listed to U.S. & Canadian standards

ELECTRICAL

Ballast Options	Electronic, Dimmable, Emergency
Emergency Lamp Options	Battery Pack or Circuit
Voltage	T8,T5,T5-HO 120, 277, 347

PRODUCT ORDERING CODE

product id	optics	length / ft	lamp	lamp config.	finish	up light	down light	ballast	voltage	circuits	other	controls	custom
ARCW PL		4	T5	2	A	0*	0*	E	120	I			
ARCW	wall	3 4 6 8 12	T8 T5 T5HO	1 one lamp 2 two lamps 3 three lamps (T5 / T5HO only)	A aluminum W white C custom	0 1 2	0 1 2	E electronic ERS rapid start D dimming (specify details)	120 277 347	1 one circuit 2 two circuits +E em. circuit	DS dust cover OS batt. pack DOS (quan./4' sections) DOS fuse (one per ballast)	DS daylight sensor OS occ. sensor DOS daylight / occ. sensor	C custom description

ASYMMETRIC SPECIFICATIONS

arc

CONFIGURATIONS

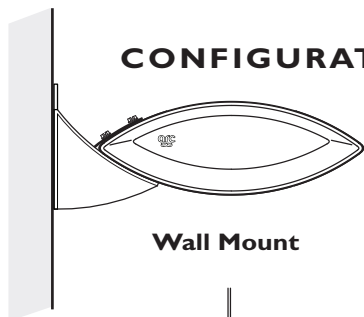

Wall Mount

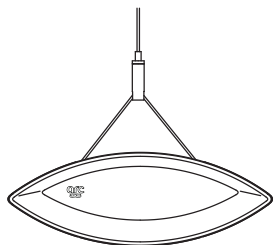

Pendant Cable

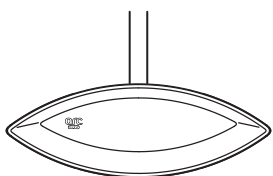

Pendant Stem

REFLECTORS

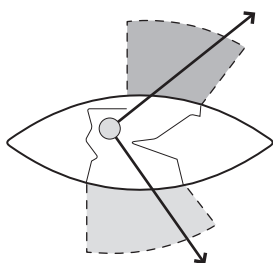

CANDLEPOWER DISTRIBUTION

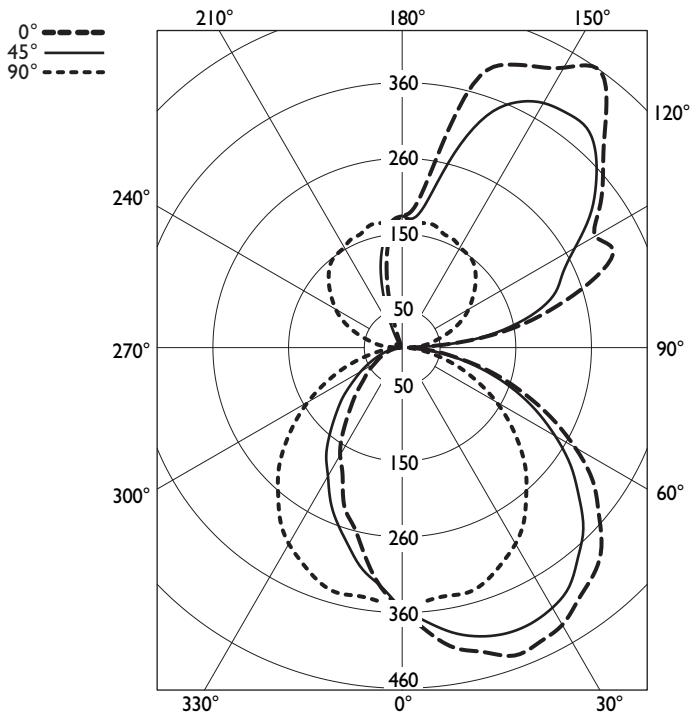

LAMPS



1 x T5 or T5H0 lamp



1 x T8 lamp

INSTALLATION PAGES

i I.1 2.4 2.5

CONSTRUCTION

End Cap	Die Cast Zinc (0.060" nominal)
Side Profile	Extruded Aluminum (0.080" nominal)
Louvers	Die Formed Semi-Specular aluminum (22 gauge)
Baffles	Die Formed Aluminum (22 gauge)
Interior Brackets	Die Formed Sheet Steel (18 gauge)
Hanger	Aircraft Cable
Suspension	Aircraft Cable or Ø 5/8" Stem
Cable Grips	Quick Connecting / Release

Finish Anodized, Powder Coated, Lacquered
Certification UL listed to U.S. & Canadian standards

ELECTRICAL

Ballast Options Electronic, Dimmable, Emergency
Emergency Emergency Battery Pack or Circuit
Lamp Options T8, T5, T5-HO
Voltage 120, 277, 347

PRODUCT ORDERING CODE

product id	center optics	length/ft	lamp	lamp config.	finish	up light	down light	ballast	voltage	circuits	suspension	hanger	other	controls	custom
ARCA	PL	4	T5	I	A	0*	0*	E	120	I	CA36	C			
ARCA asymmetric		3 4 6 8 12	T8 T5 T5HO	I one lamp	A aluminum W white C custom	0	0	E electronic ERS rapid start D dimming (specify details)	120 277 347	I one circuit 2 two circuits +E em. circuit	C cable +SM seismic		DS daylight sensor OS occ. sensor DOS daylight / occ. sensor		C custom description
SB white solid baffle	PL semi spec. para. louver	S# system								CA# cable (36" std)	D dust cover				
ES elliptical slots										CT# cable / t-bar stem (18" std) (length / inch)	B# batt. pack (quan./4' sections)				
P perf										SA#	F fuse (one per ballast)				
B blank															
F frosted															

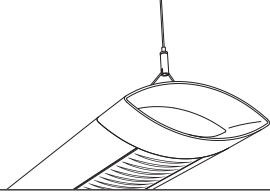

CORNER SPECIFICATIONS



In addition to individual pendants and linear runs, the **Arc** fixture can be specified with corner, T or X sections.

The corner modules are an assembly of welded aluminum extrusions. For added rigidity and secure joining, the assembly uses an internal extrusion to connect the corners to the linear sections of the system.

CORNER SPECIFICATION TIPS

PLEASE PROVIDE PLAN OR SKETCH ILLUSTRATING CORNER TYPES AND LOCATIONS REQUIRED.

Corners are to be ordered in parallel with their corresponding linear sections. Specify each corner style required with a separate code (see code below).

Mounting points are to be situated on attached linear sections as per regular pendants rather than on corners.

All systems requiring corner units must be specified as such at the time of order. Existing linear systems or fixtures cannot have corners added at a later date.

Wall mounted corners are also available. Please notify Axis with sketch and details.

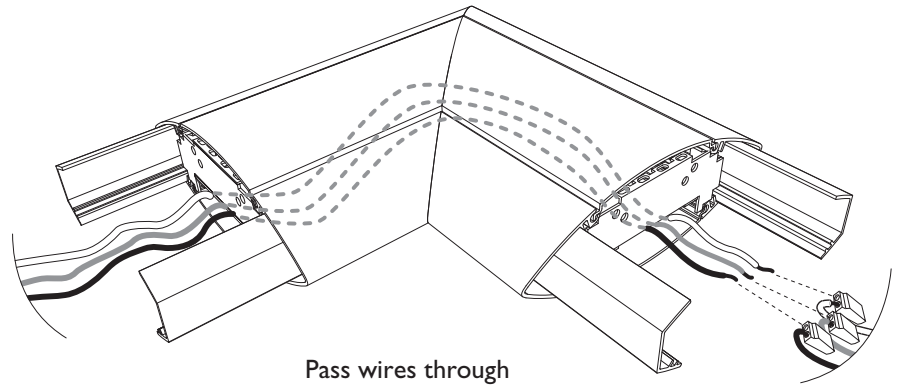

Pass wires through for a quick connection.

INSTALLATION PAGES

i 2.5

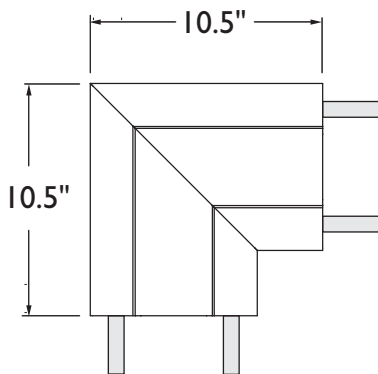

90° CORNER

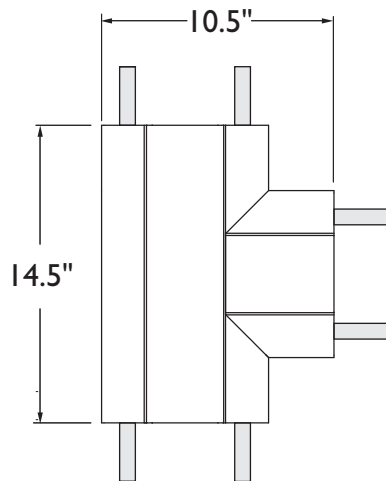

T CORNER

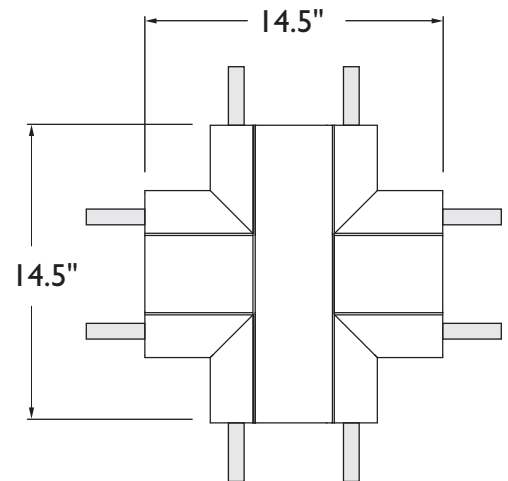

X CORNER

CORNER ORDERING CODES

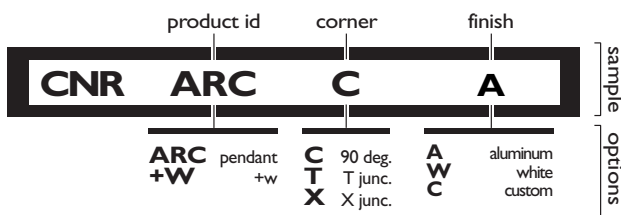

CONSTRUCTION

General Assembly
Side Profile
Center Profile
Interior Brackets
Finish
Certification

Mitered Aluminum extrusion
 Extruded Aluminum (0.080" nominal)
 Extruded Aluminum (0.080" nominal)
 Die Formed Sheet Steel (16 gauge)
 Anodized, Powder Coated, Lacquered
 UL listed to U.S. & Canadian standards



The CA, CT & SA ceiling mounting types illustrated correspond to the 'suspension' option found in the ordering code.

- 1 Support wire (by others)
- 2 Armored cable & connector (by others)
- 3 Junction box adapter bracket (by others)
- 4 4" octagon junction box (by others)
- 5 1/8" IPS Nut and washer (provided by AXIS)
- 6 1/8" IPS threaded nipple (provided by AXIS)
- 7 T-bar grid (by others)
- 8 Assembled T-bar clip (provided by AXIS)
- 9 Ceiling tile (by others)
- 10 2" canopy (provided by AXIS)
- 11 1/4"-20 crimp stud (provided by AXIS)
- 12 1/4"-20 cable holder (provided by AXIS)
- 13 Aircraft cable (provided by AXIS)
- 14 Ceiling structure (by others)
- 15 B-line J-box support (by others)
- 16 Ceiling surface material (by others)
- 17 Power cable (provided by AXIS)
- 18 1/4"-20 Threaded rod (by others)
- 19 4 1/4" canopy (provided by AXIS)
- 20 Threaded Stem (provided by AXIS)
- 21 3/8" Threaded nipple (provided by AXIS)
- 22 1/8" IPS Plastic nut (provided by AXIS)
- 23 Plastic grommet (provided by AXIS)

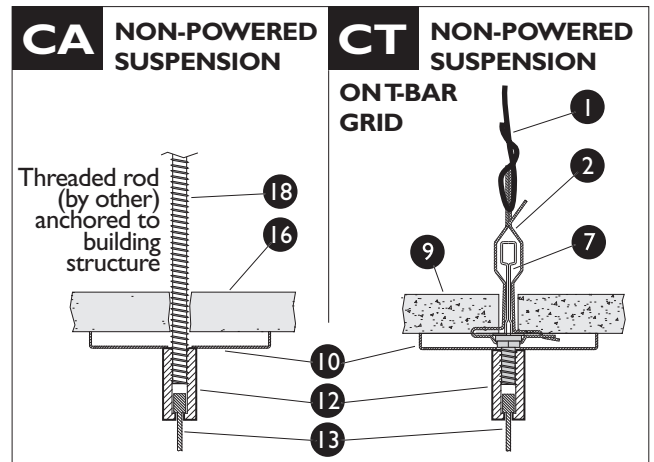
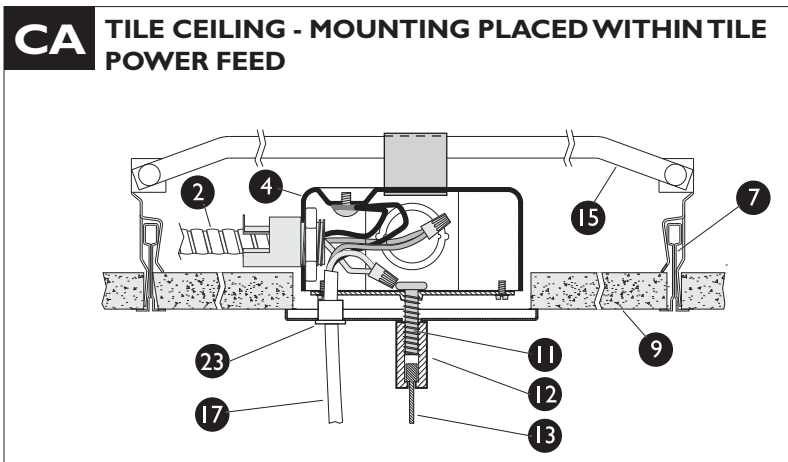
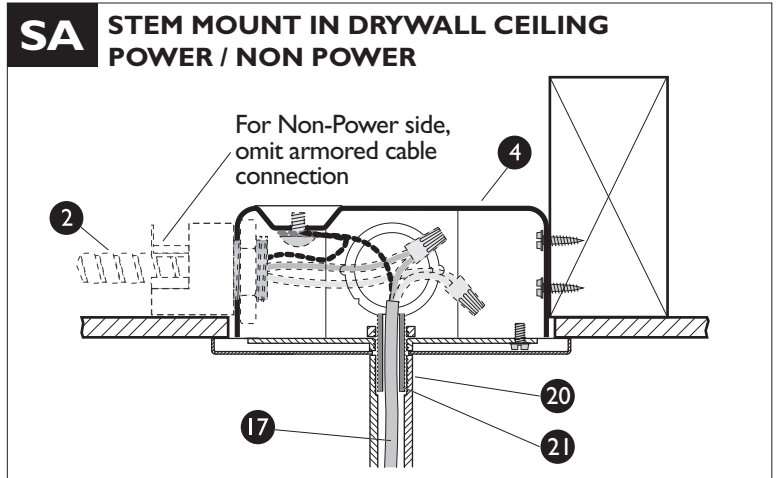
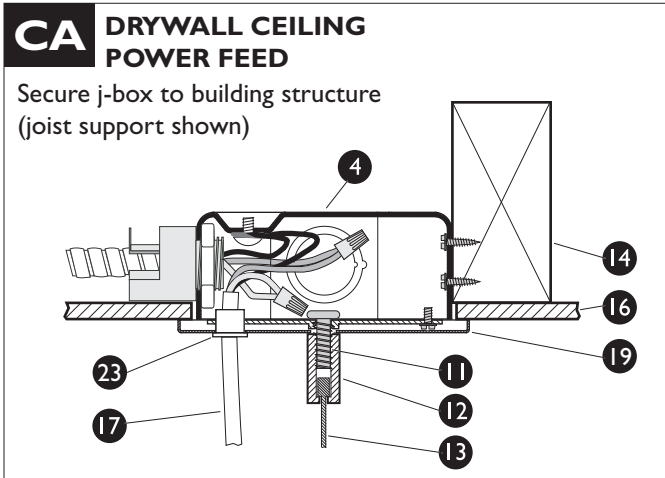
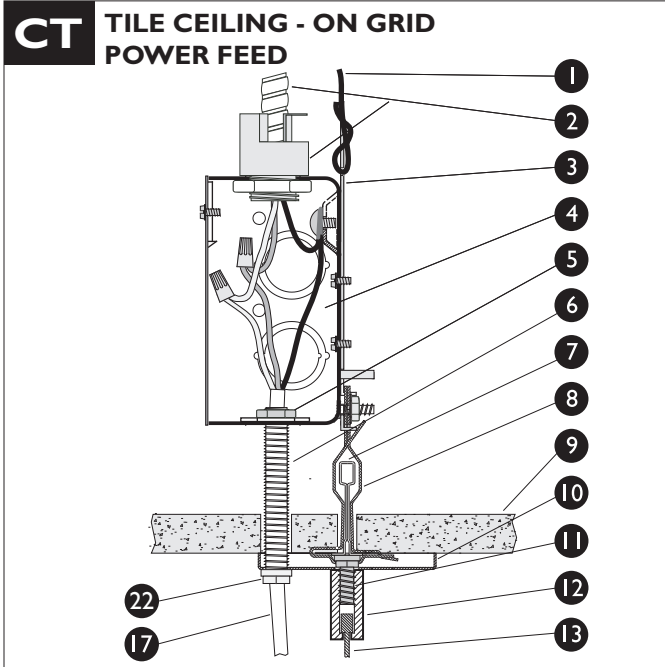

Product design and development is an on going process at Axis Lighting. We reserve the right to change specifications. Contact Axis for latest product information.

These fixtures were designed with field adjustable optic reflectors. The quantity of these uplight and downlight reflectors controls the distribution of uplight / downlight. They are specified when ordering (see product ordering code) and can be added after installation.

DOWNLIGHT REFLECTORS

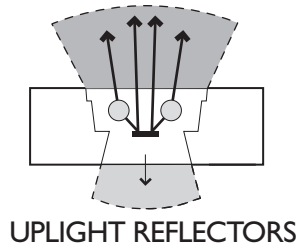
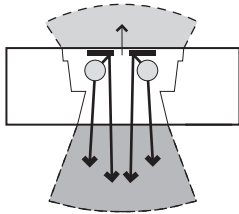

UPLIGHT REFLECTORS

The chart on the right lists available uplight / downlight ratios and their corresponding ordering code. Other light distributions may be available by custom order.

REFLECTOR INSTALLATION:

To install an **Downlight** reflector (A):

1. Position under both wire hangers (B)
2. Insert downward end tabs into desired top position holes (C)

To install an **Uplight** reflector:

1. Remove lamps (D)
2. Position reflector (A) under both wire hangers (B)
3. Insert downward end tabs into lower position holes (underneath lamp ends)
4. Replace lamps

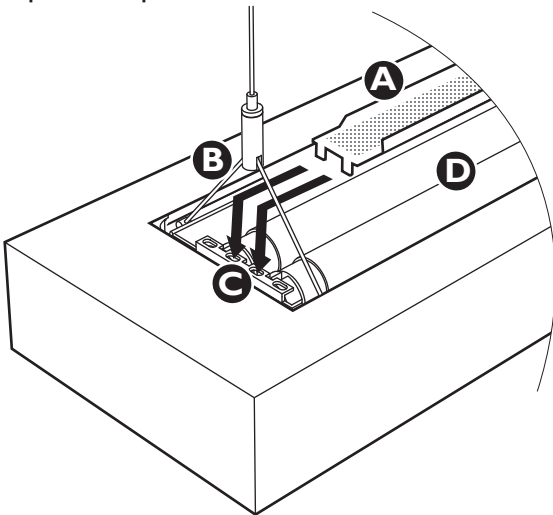

SAMPLE PRODUCT ORDERING CODE

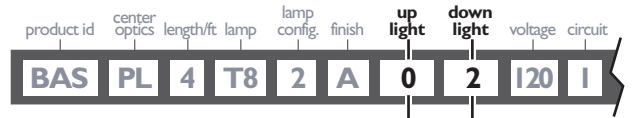

CENTER OPTIC	% UPLIGHT	% DOWNLIGHT	UPLIGHT REFLECTOR	DOWNLIGHT REFLECTOR	REFLECTOR POSITION SECTION VIEW
1 Lamp Baffle or Louver	0	100	0	BK	
	10	90	0	HP	
	20	80	0	FP	
	60	40	0	2	
	70	30	0	1	
	75	25	0	0	
	80	20	1	0	
	85	15	2	0	
	100	0	0	0	
Specify blank infill					
2 Lamps Baffle or Louver	0	100	0	BK	
	10	90	0	HP	
	20	80	0	FP	
	50	50	0	2	
	55	45	0	1	
	65	35	0	0	
	75	25	1	0	
	80	20	2	0	
	100	0	0	0	
Specify blank infill					
3 Lamps T5/T5HO Baffle or Louver	0	100	0	BK	
	10	90	0	HP	
	20	80	0	FP	
	55	45	0	2	
	65	35	0	1	
	70	30	0	0	
	80	20	1	0	
	85	15	2	0	
	100	0	0	0	
Specify blank infill					

PART LIST

- A 2"x4" junction box (by others)
- B Wall stud
- C Fixture power wire
- D Wall bracket
- E J-box power feed
- F Screws (by others)
- G Connecting tongue
- H Tongue-fixture screws
- i 1/4" connecting tongue screw

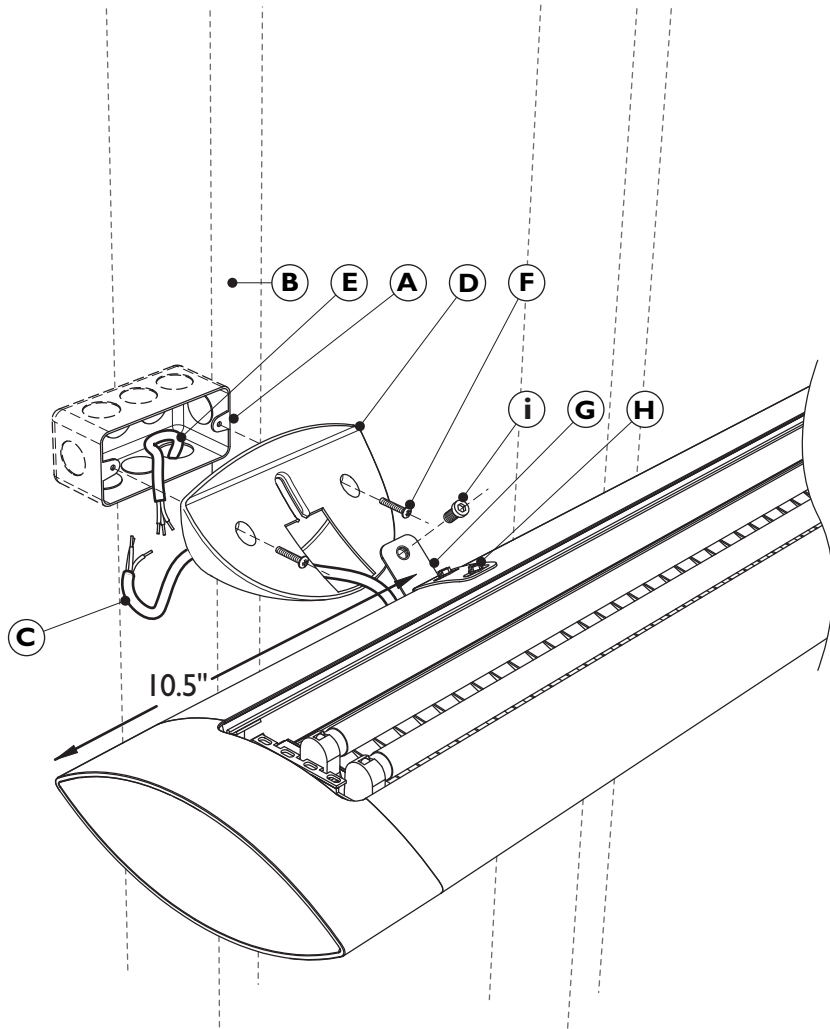

Step 4 : Placing fixture

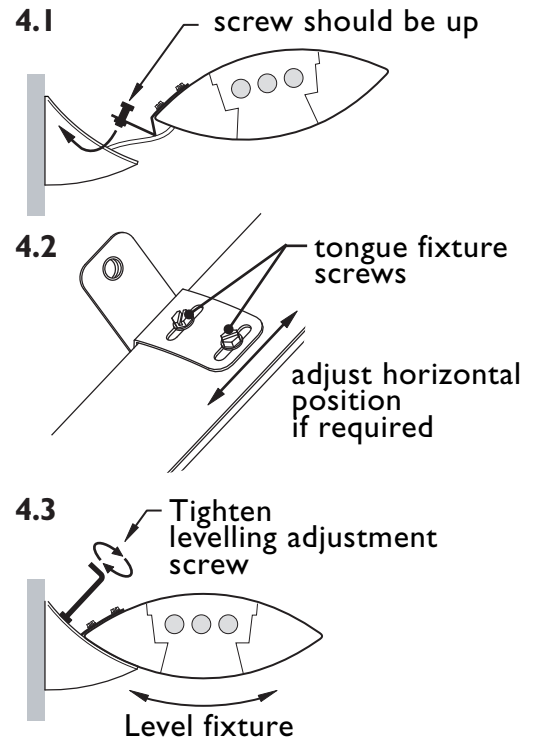

INSTALLATION OF ARC WALL FIXTURES:

- 1 **Determine fixture position :** Height should be min. 74" A.F.F. to bottom of fixture. Ensure at least 12" from ceiling to top of fixture. It is recommended to match height of suspended light fixtures if present.
- 2 **Install junction box:** Attach 2"x4" junction box (A) horizontally to left side of wall stud (B) which will be approx. 10 1/2" from left end of fixture (see above image and shop drawings). Center of junction box should be 1/2" above bottom height of fixture. Leave 8-10" of fixture power wire (C) exposed. Do not install wall bracket (D) yet.
- 3 **Install Die Cast Wall Brackets:** Pass fixture power wire through wall bracket. Connect fixture power wire to j-box power feed (E). Install wall bracket onto junction box (see above image) using appropriate screws (F).
- 4 **Placing fixture:** Tilt fixture and insert connecting tongue (G) into wall bracket, as per step 4 diagram. If connecting tongues do not align horizontally with the bracket opening, loosen tongue-fixture screws (H), adjust position, re-tighten tongue-fixture screws.
- 5 **Level:** Determine fixture level and tighten each 1/4" connecting tongue screw (i).

SYSTEM RUNS: Install each section separately on wall as per instructions above. Slide internal joining extrusions into the joining fixture and fasten the 2 horizontal nuts & bolts through the joining endplates. See page i2.15 - Pendant & System Installation Details

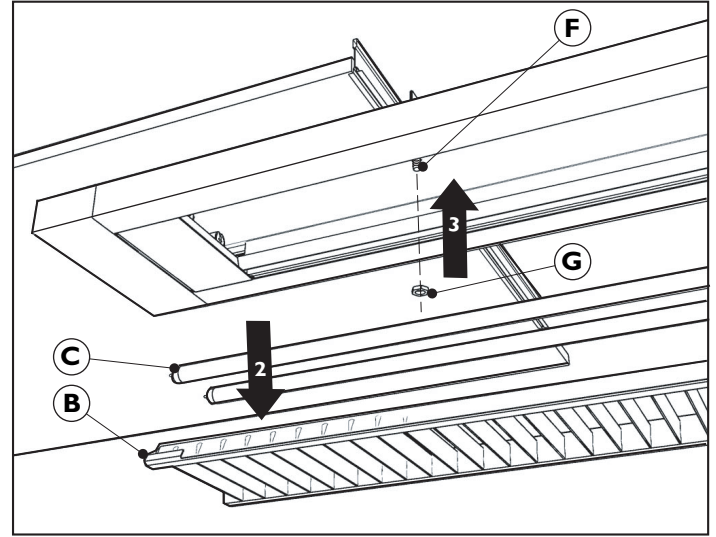
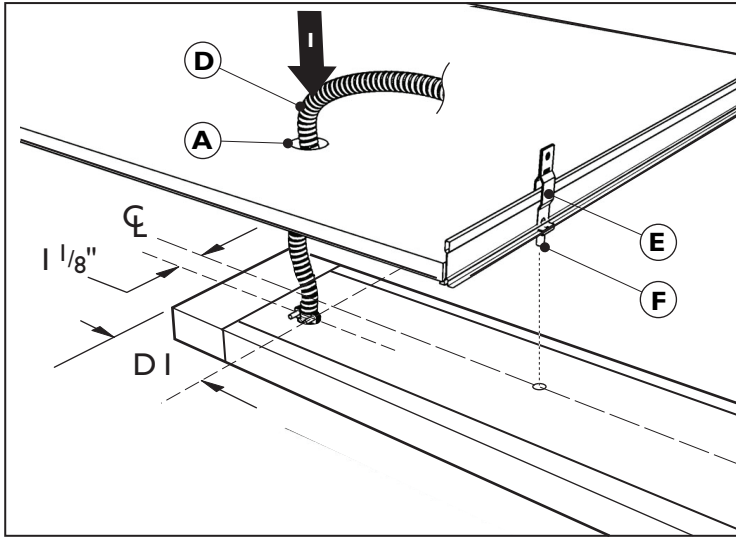

NOTE:

THE JUNCTION BOXES MUST BE SOLIDLY FIXED TO CEILING PRIOR TO FIXTURE INSTALLATION

FIXTURE ON T-BARS

- 1 Drill 1-1/2" hole (A) in the tile or drywall ceiling at D1" from end of fixture, 1-1/8" from centerline of fixture. (See chart A for dimension D1 values).
- 2 Remove louvers (B) and lamps (C) from fixture. Pass BX cable (D) through hole in ceiling and connect to solidly affixed junction box.
- 3 Hang fixture on t-bar clips (E) with 1/4 - 20 studs (F). Secure with nuts (G).
- 4 Replace louvers and lamps.

FIXTURE ON DRYWALL

- Dimensions and procedure same as above.
- T-bar clip (E) replaced with appropriate ceiling anchor (by others).
- Ensure 1/4 - 20 studs protrude from ceiling min. 3/8".

NOTE:
Available with
2 x T5 / T5HO
lamps ONLY

PART LIST

- A 1-1/2" hole
- B Louvers
- C Lamps
- D BX cable (by Axis)
- E T-bar clip (by Axis)
- F 1/4-20 stud
- G Nut

CHART A - CRITICAL DIMENSIONS

FIXTURE	D1	D2
Base	4"	53-3/8"
Sushi	3"	51-3/8"
L2	4-1/2"	54-3/8"
Cubic	4-1/2"	54-3/8"
101	3-1/8"	51-5/8"
202	3-1/8"	51-5/8"

CRITICAL DIMENSIONS

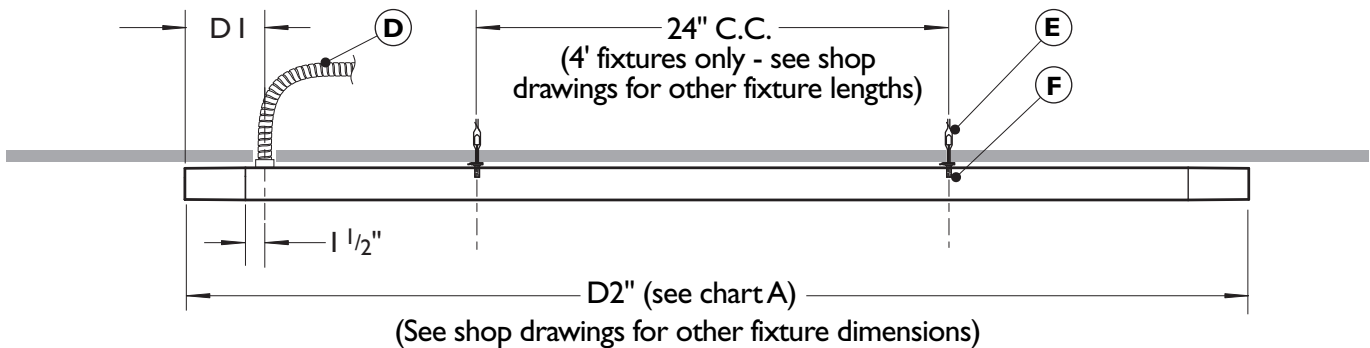

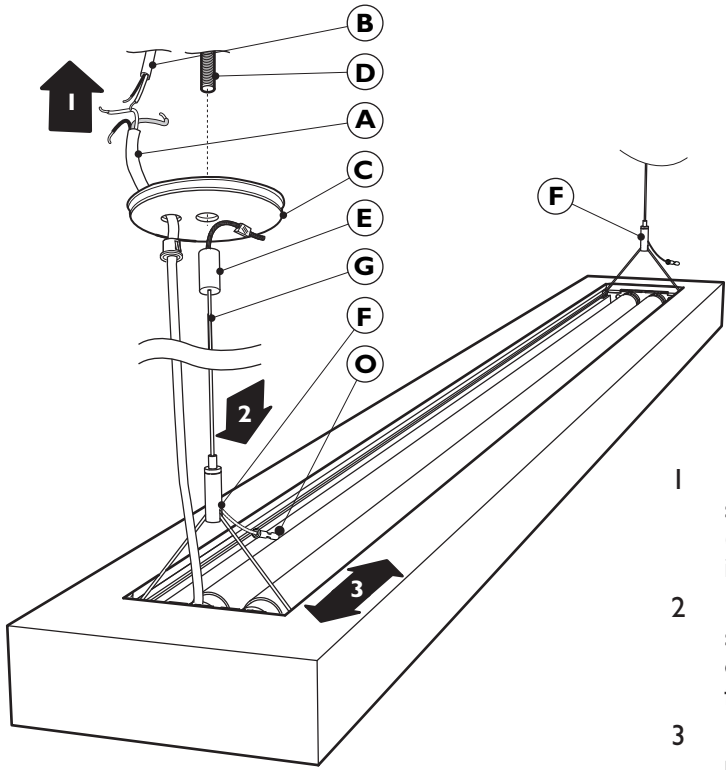

PART LIST

A Power cord	H Socket cover panel
B Ceiling power feed	i First segment
C Canopy	J Alignment extrusions
D 1/4 - 20 threaded stud	K Second segment
E Cable mounting nut	L Fixture wires
F Cable grips	M Nuts & bolts
G Braided cable	N Joining bracket
	O Ferrule

NOTE

THE JUNCTION BOXES MUST BE SOLIDLY FIXED TO CEILING PRIOR TO FIXTURE INSTALLATION

SINGLE FIXTURE INSTALLATION

- 1 Connect power cord (A) to ceiling power feed (B). At all suspension points, place canopy (C) in position on threaded stud (D) and secure with Cable mounting nut (E) with braided cable (G) in place.
- 2 Ensure that set-screws in bottom of cable grips (F) are firmly secured. Insert braided cables into the cable grips. Press on button of cable grip to level and adjust height of fixture, while moving fixture up and down.
- 3 Ensure that braided cables are vertical by sliding hanger into position. Ferrules (O) may be added to braided cables for added security.

NOTE:

HANG EACH SUCCESSIVE SYSTEM SEGMENT INDIVIDUALLY. DO NOT ASSEMBLE SYSTEM PRIOR TO HANGING.

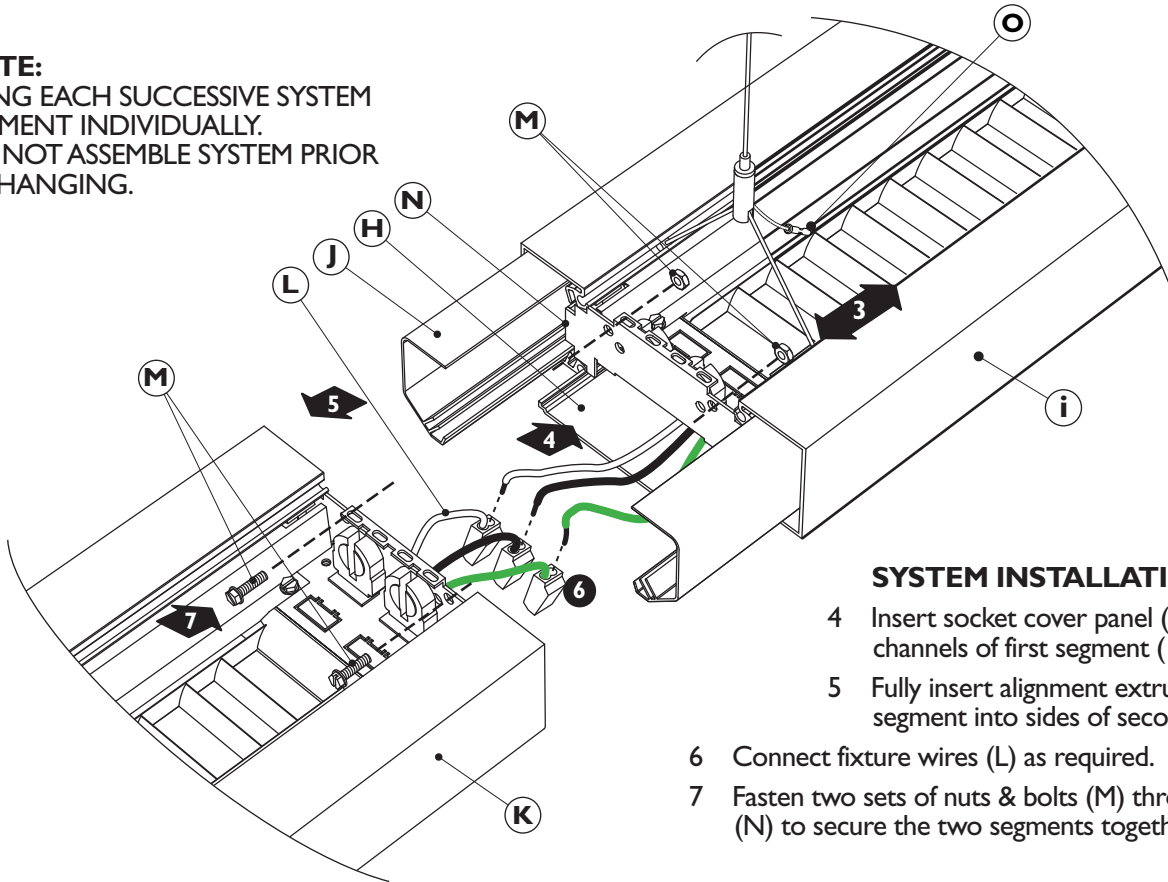

SYSTEM INSTALLATION

- 4 Insert socket cover panel (H) into bottom channels of first segment (i).
- 5 Fully insert alignment extrusions (J) of first segment into sides of second segment (K).
- 6 Connect fixture wires (L) as required.
- 7 Fasten two sets of nuts & bolts (M) through joining brackets (N) to secure the two segments together.