

L2
LINEA₂

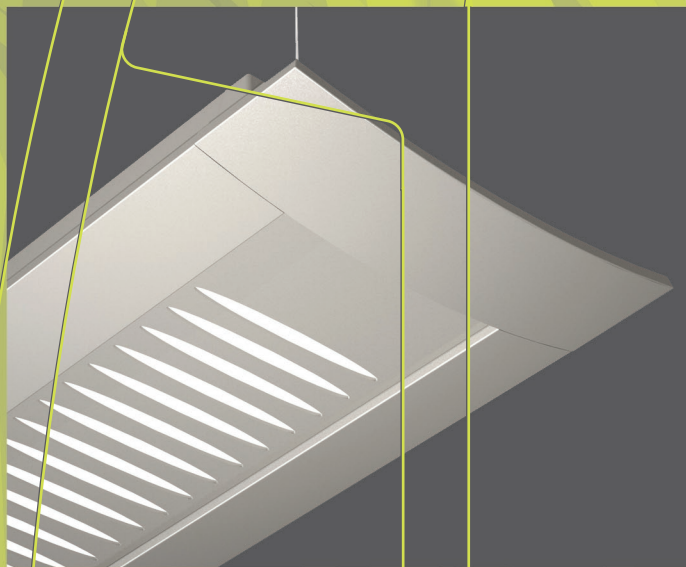

9 5/8"

2 3/8"

axis

PRODUCT ORDERING CODES

product id	center optics	length/ft	lamp	lamp config	finish	up light	down light	ballast	voltage	circuits	suspension	hanger	other	controls	custom
L2	PL	4	T5	2	A	0*	0*	E	120	1	CA36	C			
L2	pendant	3	1	one lamp		0		E	electronic	1	one circuit	C	cable	DS	daylight sensor
+W	wall	4	2	two lamps		1		ERS	rapid start	2	two circuits	D	diecast	OS	occ. sensor
+S	surface	6	3	three lamps		2		D	dimming	+E	em. circuit	+SM	seismic	DOS	daylight / occ. sensor
+A	asymmetric	8	4	four lamps (T5/T5HO only)		3			(specify details)						
		I2													
		S#	S#	system											
SB	white solid baffle		T8		A	aluminum	0	120	CA#	cable (36" std)	D	dust cover	C	custom	
PL	spec. para. louver		T5		W	white	1	277	CT#	cable / t-bar	B#	batt. pack (quan./ lumens)			
F	frosted diffuser		T5HO		C	custom	2	347	SA#	stem (18" std)	F	fuse (one per ballast)			
E	ellipse						3			(length / inch)					
P	perf						4								
S	slotted						FP								
B	blank						HP								
							BK								

sample ordering options

*Please refer to i1.2 Light Distribution Guide for up / down light reflectors specifications. For use with SB or PL center optics only.

HANGER CONFIGURATIONS

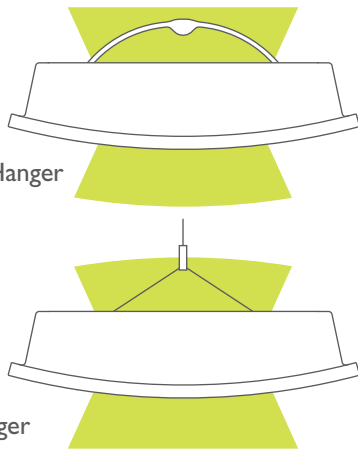

LAMP CONFIGURATIONS

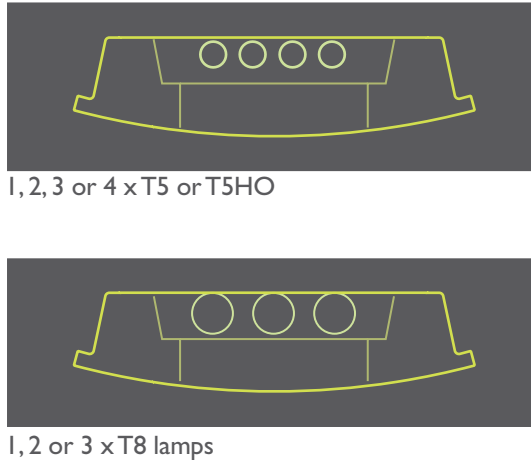

INTEGRATED CONTROLS

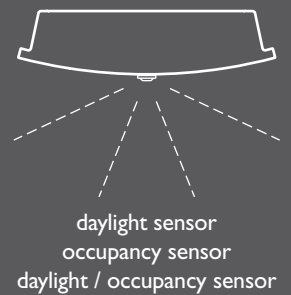

PHOTOMETRICS

Site specific lighting calculations and electronic photometric data are available at www.axislighting.com

LINEA L2™ Candlepower Distribution

Photopia Electronic Simulation
 Test Lamps: 1 x F32T8 Fluorescent
 L2-B-4-T8-1 completely indirect
 w/ MIRO Interior Reflectors Efficiency: 91.5%
 To order - specify MIRO in 'custom' field of order code

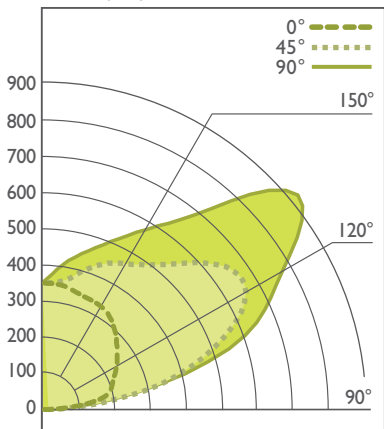

Photopia Electronic Simulation
 Test Lamps: 3 x F32T8 Fluorescent
 L2-PB-4-T8-3 indirect/direct
 w/ MIRO Interior Reflectors Efficiency 87.5%

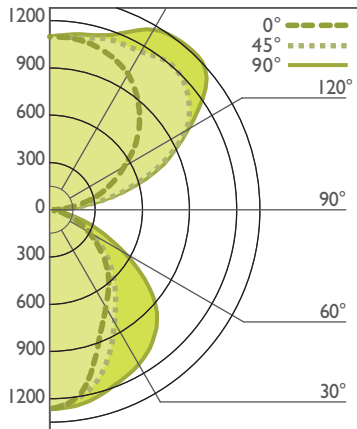

Illuminance (Footcandles)

Sample Typicals
 Code: 2 x L2-PB-24-T8-3 Reflectances:
 (2 x 24' curved w/ perf. baffles) Ceiling 80%
 Test Lamps: 3 x F32T8 Walls 50%
 Light Loss Factor: 0.8 Floor: 20%

Sample Room Layout

30' x 30' x 9' w/ work plane @ 2.5' AFF

31	34	42	49	54	52	48	45	48	52	54	49	42	34	31
32	37	50	65	74	69	59	53	59	69	74	65	50	37	32
36	43	61	84	98	89	73	64	73	89	98	84	61	43	36
38	47	68	95	112	101	82	72	82	101	112	95	68	47	38
40	50	72	100	118	107	88	77	88	107	118	100	72	50	40
41	51	75	104	122	111	91	80	91	111	122	104	75	51	41
42	53	77	106	125	114	94	83	94	114	125	106	77	53	42
41	52	76	106	124	113	93	82	93	113	124	106	76	52	41
42	53	77	106	125	114	94	83	94	114	125	106	77	53	42
41	51	75	104	122	111	91	80	91	111	122	104	75	51	41
40	50	72	100	118	107	88	77	88	107	118	100	72	50	40
38	47	68	95	112	101	82	72	82	101	112	95	68	47	38
36	43	61	84	98	89	73	64	73	89	98	84	61	43	36
32	37	50	65	74	69	59	53	59	69	74	65	50	37	32
31	34	41	49	54	52	48	45	48	52	54	49	41	34	31



PENDANT SPECIFICATIONS

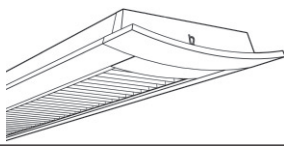

OPTICS

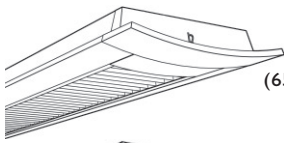

LOUVERS/BAFFLES
(65% uplight/35% downlight*)



PERF SLOTS (95% uplight/5% downlight)
ELLIPSE (90% uplight/10% downlight)
ELLIPSE (85% uplight/15% downlight)

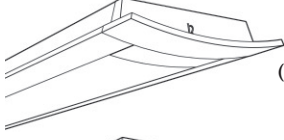

BLANK
(100% uplight/no downlight)

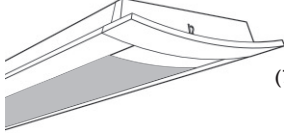

FROSTED DIFFUSER
(70% uplight/30% downlight)

CONTROLS SENSOR
(optional)

MOUNTING POINT SPACING
4' (48")
8' (96")
12' (144")

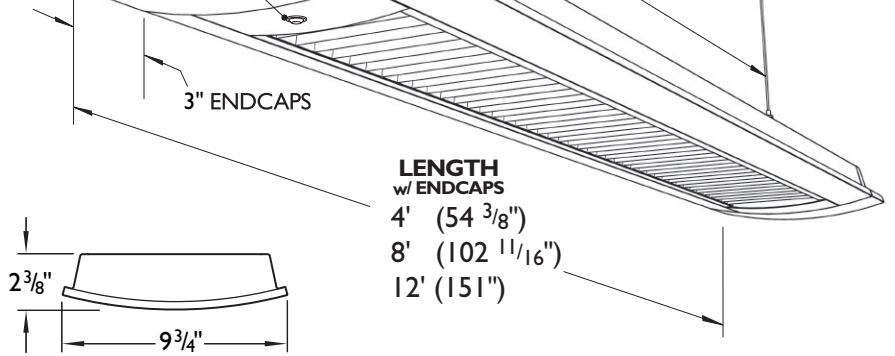

LENGTH w/ ENDCAPS
4' (54 3/8")
8' (102 11/16")
12' (151")

HANGER

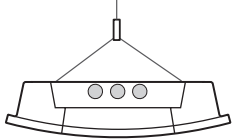

adjustable cable hanger

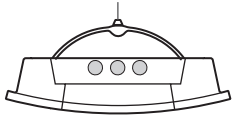

Die-cast Hanger

LAMPS

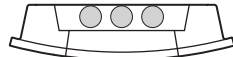

1, 2 or 3 x T8 lamps

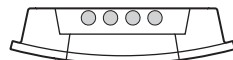

1, 2, 3 or 4 x T5/T5HO

REFLECTORS

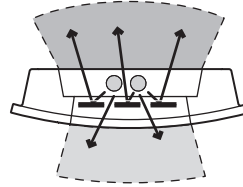

* Refer to page i1.2 - "Light Distribution Guide" for customizing uplight/downlight ratios with variable reflectors

INSTALLATION PAGES

i 1.1 1.2 2.5

CONSTRUCTION

End Cap	Die Cast Zinc (0.100" nominal)
Side Profile	Extruded Aluminum (0.100" nominal)
Louvers	Die Formed Semi-Specular aluminum (22 gauge)
Baffles	Die Formed Aluminum (22 gauge)
Interior Brackets	Die Formed Sheet Steel (18 gauge)
Hanger	Aircraft Cable
Suspension	Aircraft Cable or Ø 5/8" Stem
Cable Grips	Quick Connecting / Release

Finish Certification

Anodized, Powder Coated, Lacquered
UL listed to U.S. & Canadian standards

ELECTRICAL

Ballast Options
Emergency Lamp Options
Voltage

Electronic or Dimmable
Emergency Battery Pack or Circuit
T8, T5, T5-HO
120, 277, 347

PRODUCT ORDERING CODE

product id	optics	length/ft	lamp	lamp config.	finish	up light	down light	ballast	voltage	circuits	suspension	hanger	other	controls	custom
L2	PL	4	T5	2	A	0*	0*	E	120	1	CA36	C			
L2	pendant	3 4 6 8 12 S# system	1 2 3 4 (T5 / T5HO only)	one lamp two lamps three lamps four lamps	A W C	0 1 2 3	0 1 2 3 4 FP HP BK	E ERS D	120 277 347	1 2 +E	CA# CT# SA#	D C + SM	DS OS DOS		C
	white solid baffle		T8 T5 T5HO		aluminum white custom			electronic rapid start dimming (specify details)		one circuit two circuits em. circuit	cable (36" std) cable / t-bar stem (18" std) (length / inch)	die-cast cable seismic	daylight sensor occ. sensor daylight / occ. sensor		custom description
	semi spec. para. louver												dust cover batt. pack (quan./4 sections) fuse (one per ballast)		
	frosted diffuser														
	ellipse														
	perf														
	slotted														
	blank														

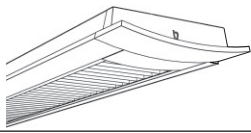

WALL MOUNT SPECIFICATIONS

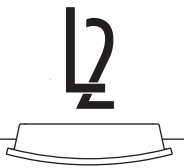

OPTICS

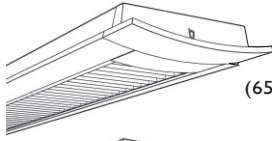

LOUVERS/BAFFLES
(65% uplight/35% downlight*)



PERF (95% uplight/5% downlight)
SLOTS (90% uplight/10% downlight)
ELLIPSE (85% uplight/15% downlight)

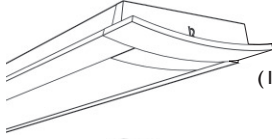

BLANK
(100% uplight/no downlight)

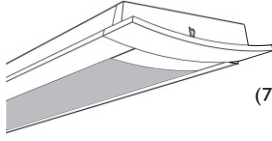

FROSTED DIFFUSER
(70% uplight/30% downlight)



CONTROLS SENSOR
(optional)

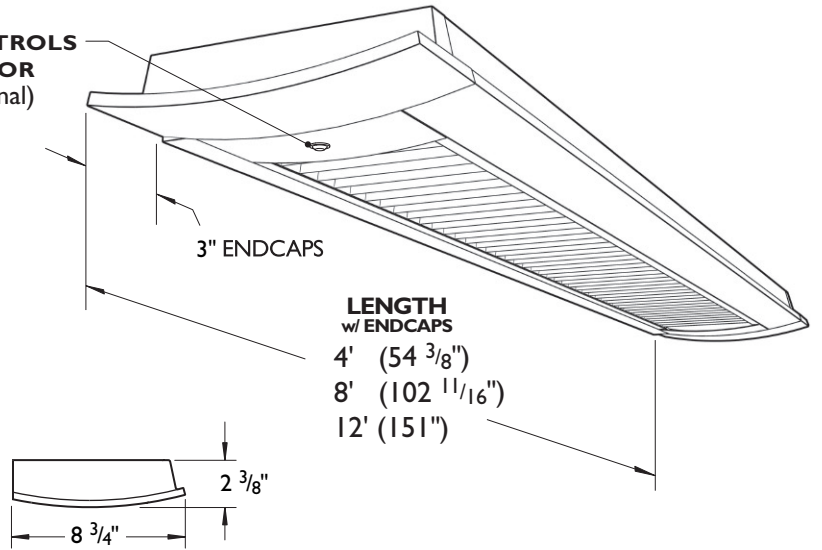

REFLECTORS

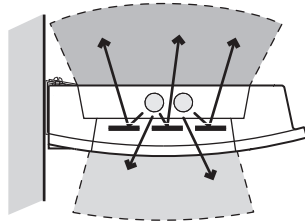

* Refer to page i1.2 - "Light Distribution Guide" for customizing uplight/downlight ratios with variable reflectors

LAMPS

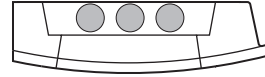

1, 2 or 3 x T8 lamps

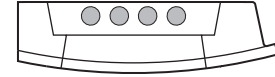

1, 2, 3 or 4 x T5/T5HO

INSTALLATION PAGES

i 1.1 1.2 2.7

CONSTRUCTION

End Cap	Die Cast Zinc (0.100" nominal)
Side Profile	Extruded Aluminum (0.100" nominal)
Louvers	Die Formed Semi-Specular aluminum (22 gauge)
Baffles	Die Formed Aluminum (22 gauge)
Interior Brackets	Die Formed Sheet Steel (18 gauge)
Hanger	Aircraft Cable
Suspension	Aircraft Cable or Ø 5/8" Stem
Cable Grips	Quick Connecting / Release

Finish Certification

Anodized, Powder Coated, Lacquered
UL listed to U.S. & Canadian standards

ELECTRICAL

Ballast Options	Electronic or Dimmable
Emergency	Emergency Battery Pack or Circuit
Lamp Options	T8, T5, T5-HO
Voltage	120, 277, 347

PRODUCT ORDERING CODE

product id	optics	length/ft	lamp	lamp config.	finish	up light	down light	ballast	voltage	circuits	other	controls	custom
L2W	PL	4	T5	2	A	0*	0*	E	120	I			
L2W wall	3 white solid baffle 4 semi spec. para. louver 6 frosted diffuser 8 ellipse 12 perf S# slotted I2 blank	4 system	1 one lamp 2 two lamps 3 three lamps 4 four lamps (T5/T5HO only)	T8 T5 T5HO	A aluminum W white C custom	0 1 2 3	0 1 2 3 4 FP HP BK	E electronic ERS rapid start D dimming (specify details)	120 277 347	1 one circuit 2 two circuits +E em. circuit	D dust cover B# batt. pack F (quan./4' sections) F fuse (one per ballast)	DS daylight sensor OS occ. sensor DOS daylight / occ. sensor	C custom description

sample
ordering options

SURFACE MOUNT SPECIFICATIONS



OPTICS

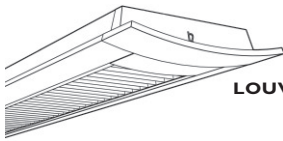

LOUVERS/BAFFLES
(100% downlight)

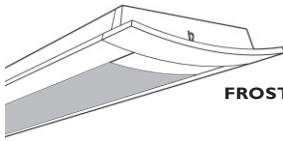

FROSTED DIFFUSER
(100% downlight)



CONTROLS SENSOR
(optional)

NOTE:
Available with
2 x T5 / T5HO
lamps **ONLY**

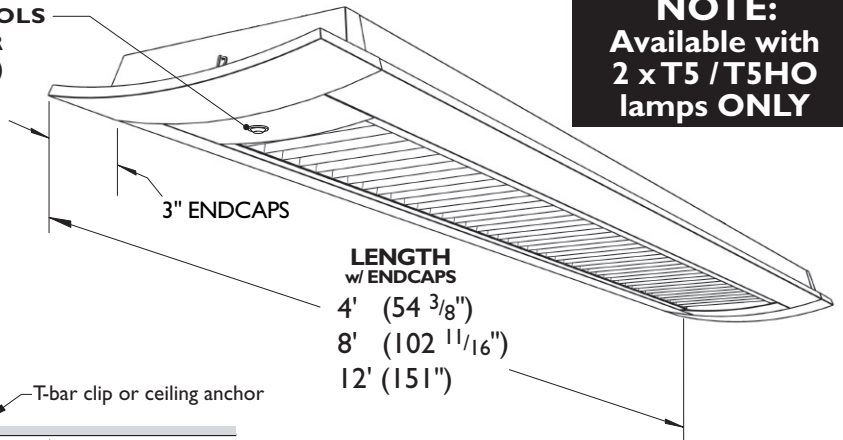

3" ENDCAPS

**LENGTH
w/ ENDCAPS**

- 4' (54 3/8")
- 8' (102 11/16")
- 12' (151")

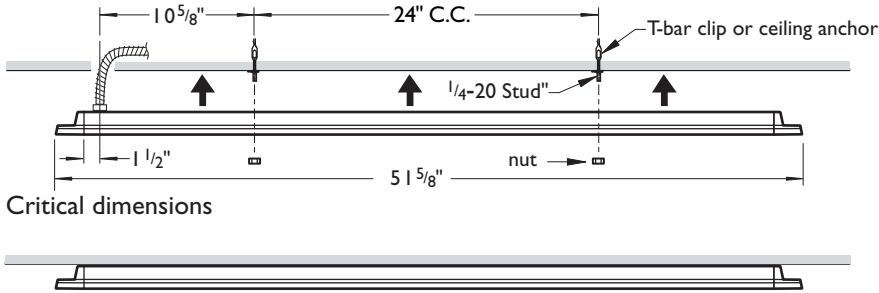

Critical dimensions

Side view (final position)

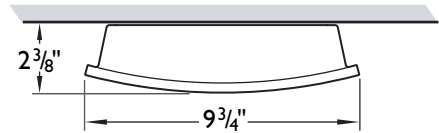

LAMPS



2 x T5/T5HO
(T8 not available)

LIGHT DISTRIBUTION

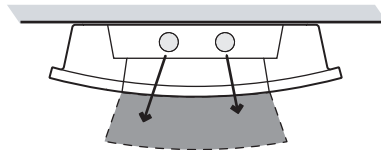

100% Down Light

INSTALLATION PAGE



CONSTRUCTION

End Cap	Die Cast Zinc (0.100" nominal)
Side Profile	Extruded Aluminum (0.100" nominal)
Louvers	Die Formed Semi-Specular aluminum (22 gauge)
Baffles	Die Formed Aluminum (22 gauge)
Interior Brackets	Die Formed Sheet Steel (18 gauge)
Hanger	Aircraft Cable
Suspension	Aircraft Cable or Ø 5/8" Stem
Cable Grips	Quick Connecting / Release

Finish Anodized, Powder Coated, Lacquered
Certification UL listed to U.S. & Canadian standards

ELECTRICAL

Ballast Options Electronic, Dimmable, Emergency
Emergency Lamp Options Emergency Battery Pack or Circuit
Voltage T8, T5, T5-HO
 120, 277, 347

PRODUCT ORDERING CODE

product id	optics	length/ft	lamp	lamp config.	finish	up light	down light	ballast	voltage	circuits	other	controls	custom
L2S	PL	4	T5HO	2	A	0	BK	E	120	I			
L2S surface	3 4 6 8 12 S# system		2 two lamps (T5 / T5HO only)		A aluminum W white C custom	0	BK	E electronic ERS rapid start D dimming (specify details)	120 277 347	1 one circuit 2 two circuits +E em. circuit	DS daylight sensor OS occ. sensor DOS daylight / occ. sensor		
SB white solid baffle PL semi spec. para. louver F frosted diffuser			T5 T5HO (T5 / T5HO only)							B# batt. pack (quan. / lumens) F fuse (one per ballast)		C custom description	

sample
ordering options



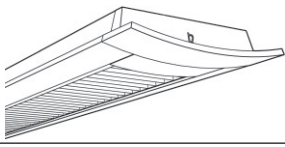

ASYMMETRIC SPECIFICATIONS

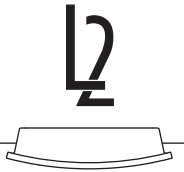

CONFIGURATIONS

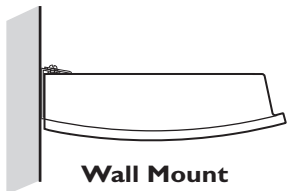
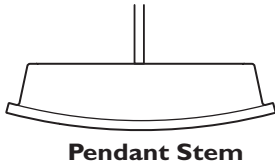
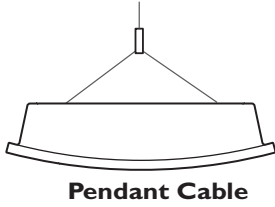

0° - - - -
45° - - - -
90° - - - -

REFLECTORS

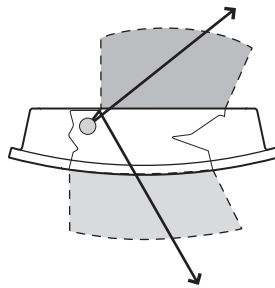

CANDLEPOWER DISTRIBUTION

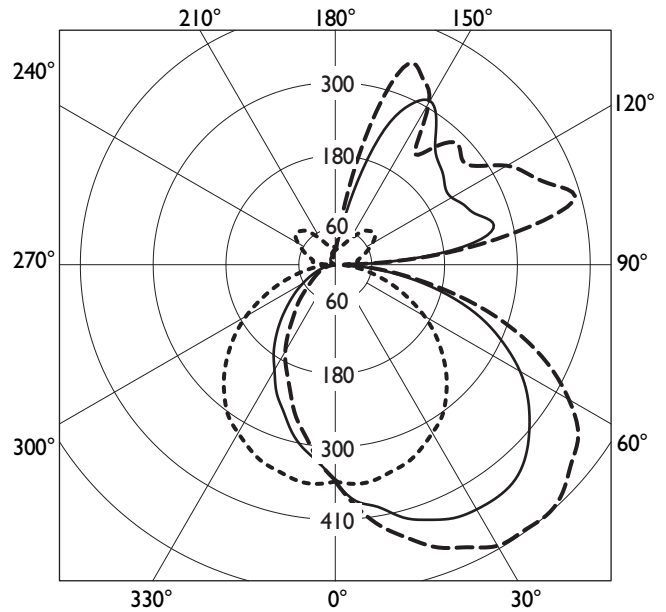

LAMPS

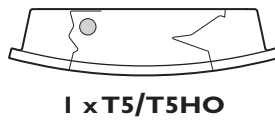
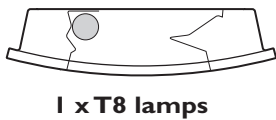

INSTALLATION PAGES

i 1.1 2.5 2.7

CONSTRUCTION

End Cap	Die Cast Zinc (0.100" nominal)
Side Profile	Extruded Aluminum (0.100" nominal)
Louvers	Die Formed Semi-Specular aluminum (22 gauge)
Baffles	Die Formed Aluminum (22 gauge)
Interior Brackets	Die Formed Sheet Steel (18 gauge)
Hanger	Aircraft Cable
Suspension	Aircraft Cable or Ø 5/8" Stem
Cable Grips	Quick Connecting / Release

Finish Anodized, Powder Coated, Lacquered
Certification UL listed to U.S. & Canadian standards

ELECTRICAL

Ballast Options	Electronic or Dimmable
Emergency	Emergency Battery Pack or Circuit
Lamp Options	T8, T5, T5-HO
Voltage	120, 277, 347

PRODUCT ORDERING CODE

product id	optics	length/ft	lamp	lamp config.	finish	up light	down light	ballast	voltage	circuits	suspension	hanger	other	controls	custom
L2A	F	4	T5	I	A	0	0	E	120	I	CA36	C			
L2A asymmetric	F frosted diffuser	3 4 6 8 12 S# system	T8 T5 T5HO	I one lamp	A aluminum W white C custom	0	0	E electronic rapid start dimming (specify details) ERS D	120 277 347	I one circuit 2 two circuits +E em. circuit	CA# cable (36" std) CT# cable / t-bar stem (18" std) (length / inch)	D die-cast cable seismic C +SM	DS daylight sensor OS occ. sensor DOS daylight / occ. sensor		C custom description

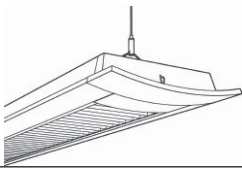

CORNER SPECIFICATIONS

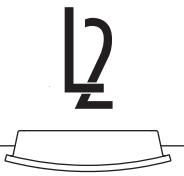

In addition to individual pendants and linear runs, the L2 fixture can be specified with corner, T or X sections.

The corner modules are an assembly of welded aluminum extrusions. For added rigidity and a secure joining, the assembly uses an internal extrusion to connect the corners and linear sections of the system.

CORNER SPECIFICATION TIPS

PLEASE PROVIDE PLAN OR SKETCH ILLUSTRATING CORNER TYPES AND LOCATIONS REQUIRED.

Corners are to be ordered in parallel with their corresponding linear sections. Specify each corner style required with a separate code, (see code below).

Mounting points are to be situated on attached linear sections as per regular pendants rather than on corners.

All systems requiring corner units must be specified as such at the time of order. Existing linear systems or fixtures cannot have corners added at a later date.

Wall mounted corners are also available. Please notify Axis with sketch and details.

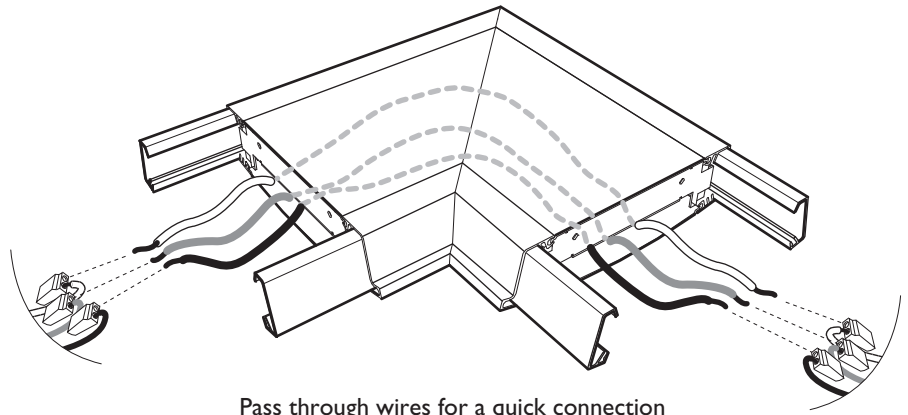

Pass through wires for a quick connection

INSTALLATION PAGE

i 2.5

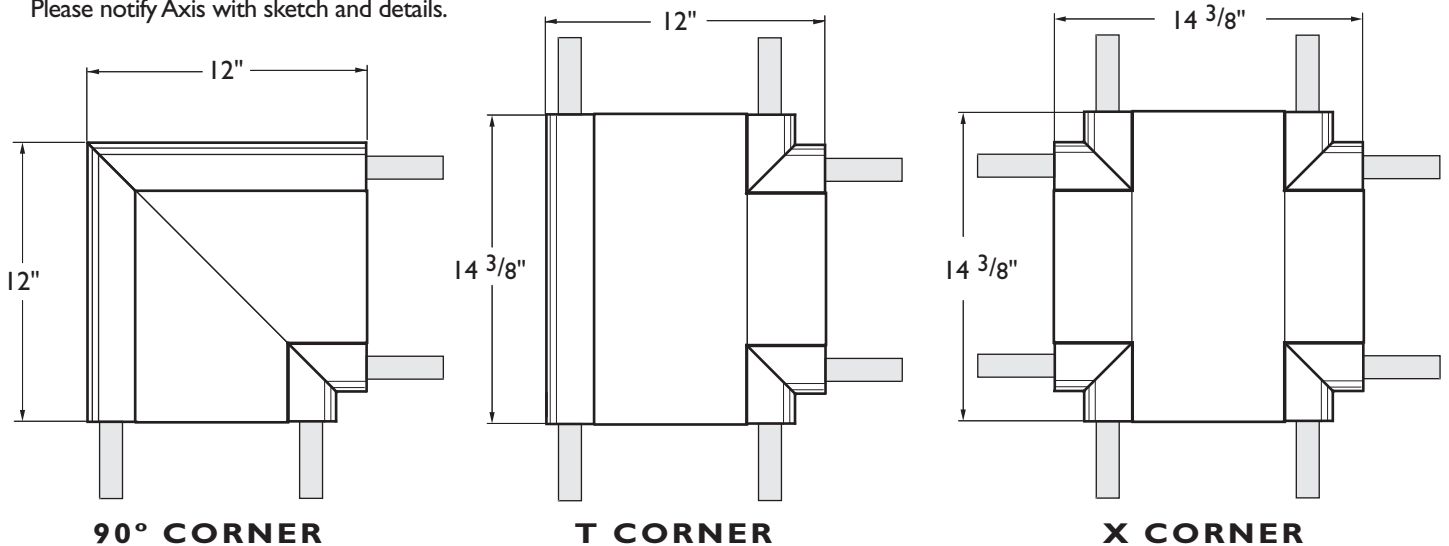

CORNER ORDERING CODES

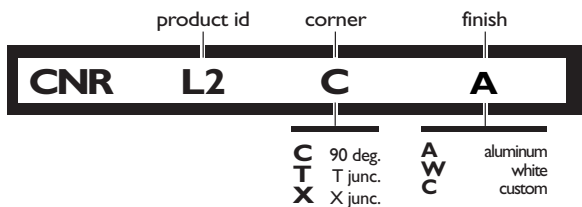

CONSTRUCTION

General Assembly
Side Profile
Center Profile
Interior Brackets
Finish
Certification

Mitered Aluminum extrusion
 Extruded Aluminum (0.100" nominal)
 Extruded Aluminum (0.080" nominal)
 Die Formed Sheet Steel (16 gauge)
 Anodized, Powder Coated, Lacquered
 UL listed to U.S. & Canadian standards

The CA, CT & SA ceiling mounting types illustrated correspond to the 'suspension' option found in the ordering code.

- 1 Support wire (by others)
- 2 Armored cable & connector (by others)
- 3 Junction box adapter bracket (by others)
- 4 4" octagon junction box (by others)
- 5 1/8" IPS Nut and washer (provided by AXIS)
- 6 1/8" IPS threaded nipple (provided by AXIS)
- 7 T-bar grid (by others)
- 8 Assembled T-bar clip (provided by AXIS)
- 9 Ceiling tile (by others)
- 10 2" canopy (provided by AXIS)
- 11 1/4"-20 crimp stud (provided by AXIS)
- 12 1/4"-20 cable holder (provided by AXIS)
- 13 Aircraft cable (provided by AXIS)
- 14 Ceiling structure (by others)
- 15 B-line J-box support (by others)
- 16 Ceiling surface material (by others)
- 17 Power cable (provided by AXIS)
- 18 1/4"-20 Threaded rod (by others)
- 19 4 1/4" canopy (provided by AXIS)
- 20 Threaded Stem (provided by AXIS)
- 21 3/8" Threaded nipple (provided by AXIS)
- 22 1/8" IPS Plastic nut (provided by AXIS)
- 23 Plastic grommet (provided by AXIS)

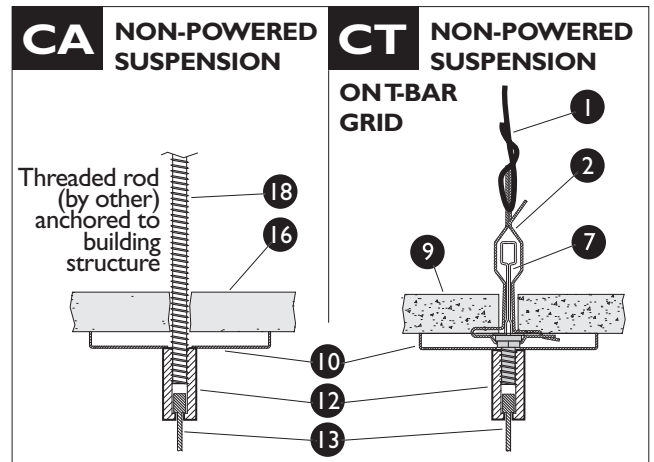
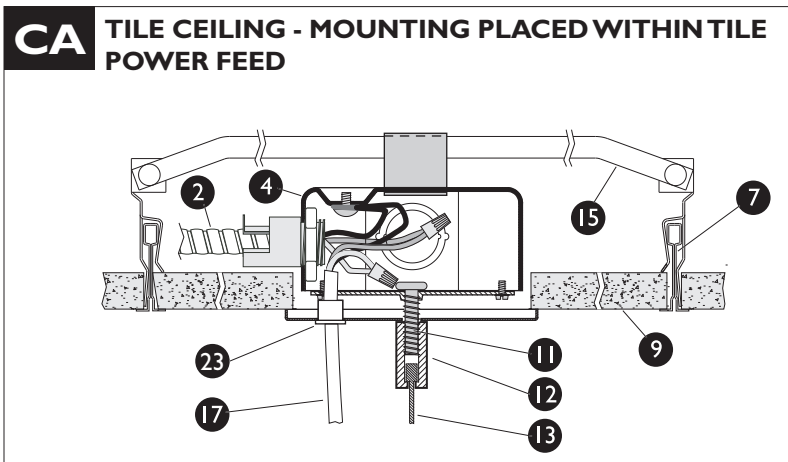
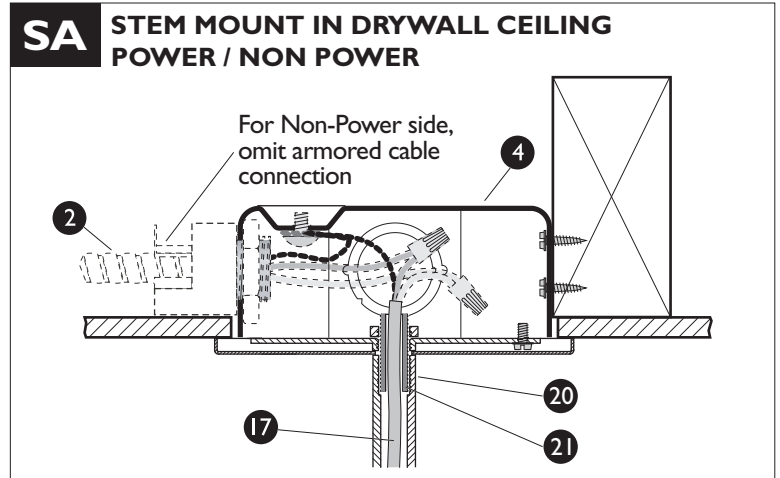
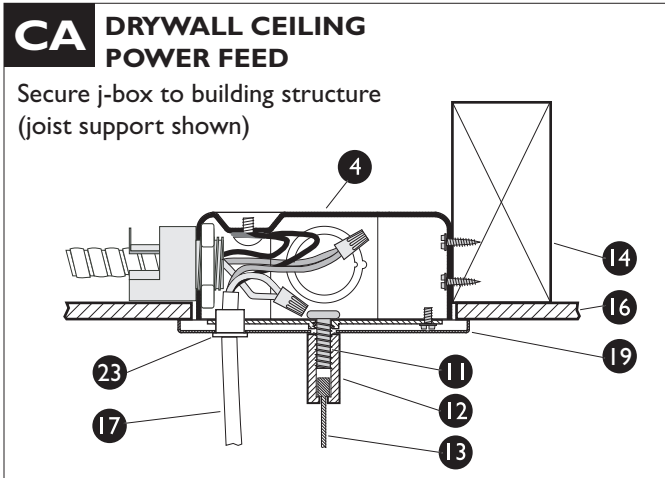
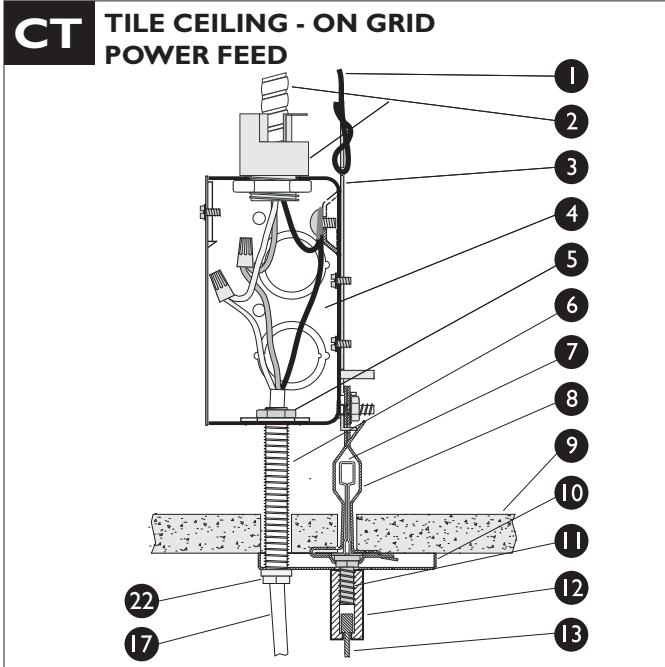

These fixtures were designed with field adjustable optic reflectors. The quantity of these uplight and downlight reflectors controls the distribution of uplight / downlight. They are specified when ordering (see product ordering code) and can be added after installation.

DOWNLIGHT REFLECTORS

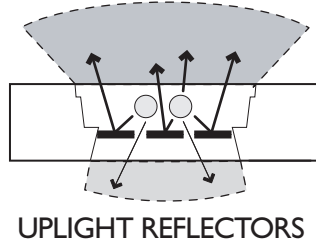
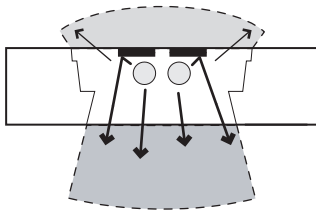

The chart on the right lists available uplight / downlight ratios and their corresponding ordering code. Other light distributions may be available by custom order.

REFLECTOR INSTALLATION:

To install an **Downlight** reflector (A):

1. Position under both wire hangers (B)
2. Insert downward end tabs into desired top position holes (C)

To install an **Uplight** reflector:

1. Remove lamps (D)
2. Position reflector (A) under both wire hangers (B)
3. Insert downward end tabs into lower position holes (underneath lamp ends)
4. Replace lamps

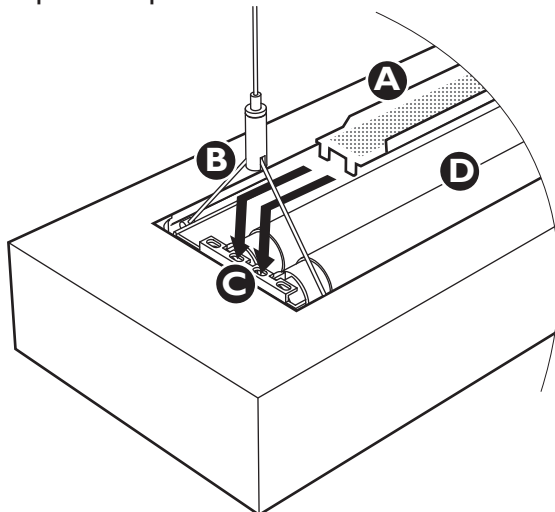

SAMPLE PRODUCT ORDERING CODE

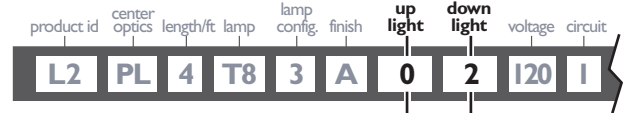

LAMPS CENTER OPTIC	% UPLIGHT	% DOWNLIGHT	UPLIGHT REFLECTOR	DOWNLIGHT REFLECTOR	REFLECTOR POSITION SECTION VIEW
1 Lamp Baffle or Louver	0	100	0	BK	
	10	90	0	HP	
	20	80	0	FP	
	50	50	0	4	
	55	45	0	3	
	60	40	0	2	
	70	30	0	1	
	75	25	0	0	
	80	20	1	0	
	85	15	2	0	
90	10	3	0		
100	0	0	0		Specify blank infill
2 Lamps Baffle or Louver	0	100	0	BK	
	10	90	0	HP	
	20	80	0	FP	
	40	60	0	4	
	45	55	0	3	
	50	50	0	2	
	60	40	0	1	
	65	35	0	0	
	70	30	1	0	
	75	25	2	0	
80	20	3	0		
100	0	0	0		Specify blank infill
3 Lamps Baffle or Louver	0	100	0	BK	
	10	90	0	HP	
	20	80	0	FP	
	40	60	0	4	
	45	55	0	3	
	50	50	0	2	
	55	45	0	1	
	60	40	0	0	
	65	35	1	0	
	70	30	2	0	
75	25	3	0		
100	0	0	0		Specify blank infill

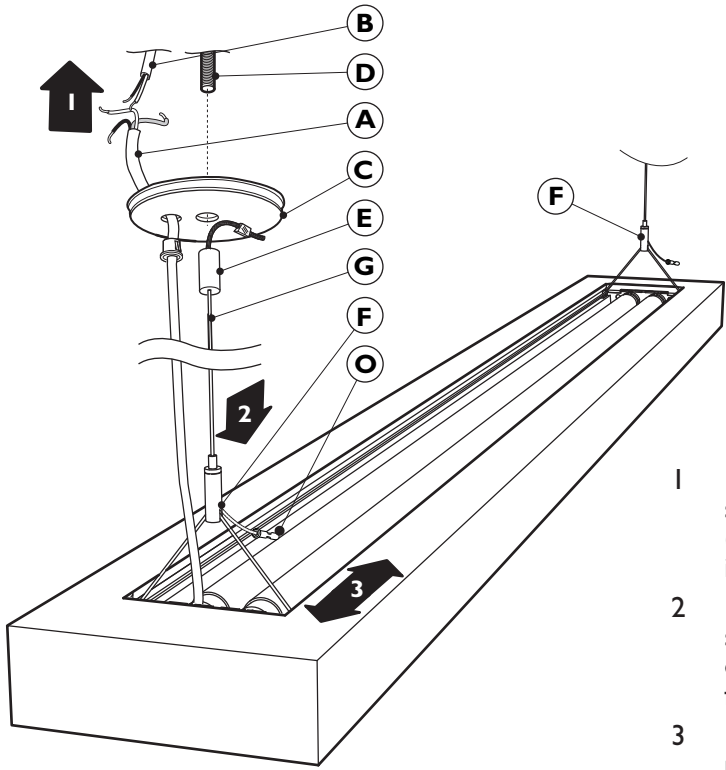

PART LIST

A Power cord	H Socket cover panel
B Ceiling power feed	i First segment
C Canopy	J Alignment extrusions
D 1/4 - 20 threaded stud	K Second segment
E Cable mounting nut	L Fixture wires
F Cable grips	M Nuts & bolts
G Braided cable	N Joining bracket
	O Ferrule

NOTE

THE JUNCTION BOXES MUST BE SOLIDLY FIXED TO CEILING PRIOR TO FIXTURE INSTALLATION

SINGLE FIXTURE INSTALLATION

- 1 Connect power cord (A) to ceiling power feed (B). At all suspension points, place canopy (C) in position on threaded stud (D) and secure with Cable mounting nut (E) with braided cable (G) in place.
- 2 Ensure that set-screws in bottom of cable grips (F) are firmly secured. Insert braided cables into the cable grips. Press on button of cable grip to level and adjust height of fixture, while moving fixture up and down.
- 3 Ensure that braided cables are vertical by sliding hanger into position. Ferrules (O) may be added to braided cables for added security.

NOTE:
 HANG EACH SUCCESSIVE SYSTEM
 SEGMENT INDIVIDUALLY.
 DO NOT ASSEMBLE SYSTEM PRIOR
 TO HANGING.

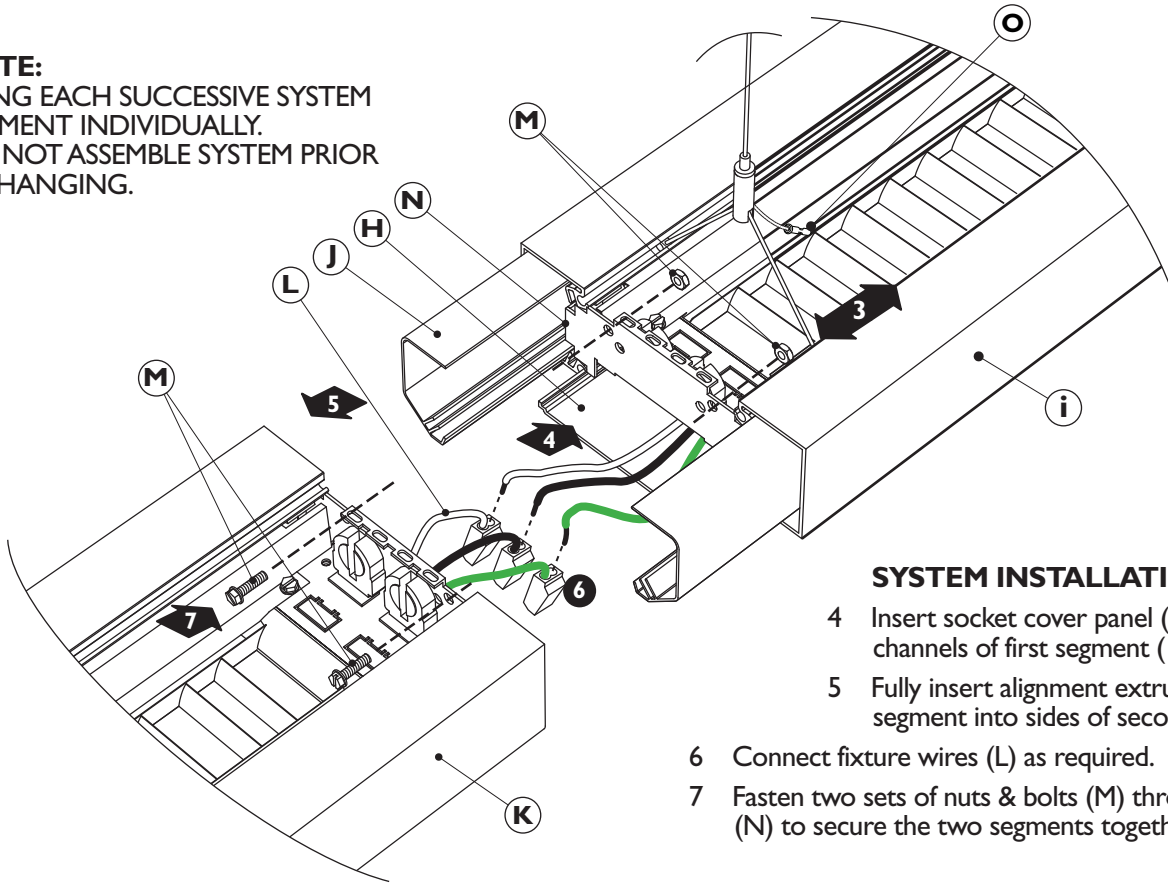

SYSTEM INSTALLATION

- 4 Insert socket cover panel (H) into bottom channels of first segment (i).
- 5 Fully insert alignment extrusions (J) of first segment into sides of second segment (K).
- 6 Connect fixture wires (L) as required.
- 7 Fasten two sets of nuts & bolts (M) through joining brackets (N) to secure the two segments together.

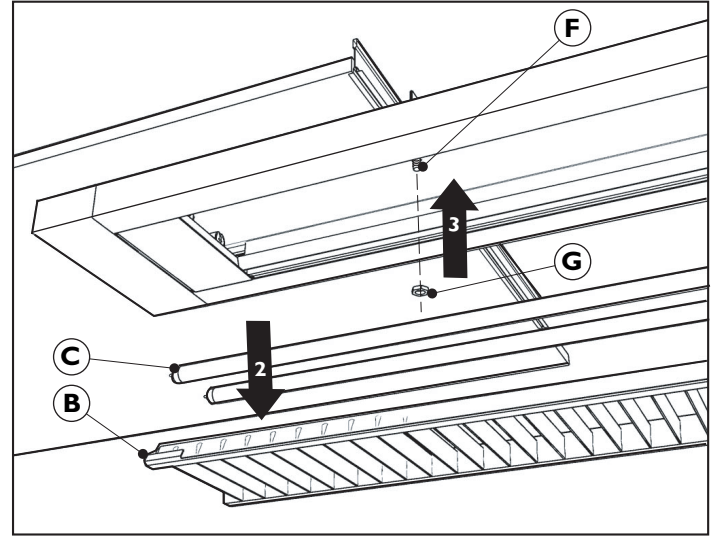
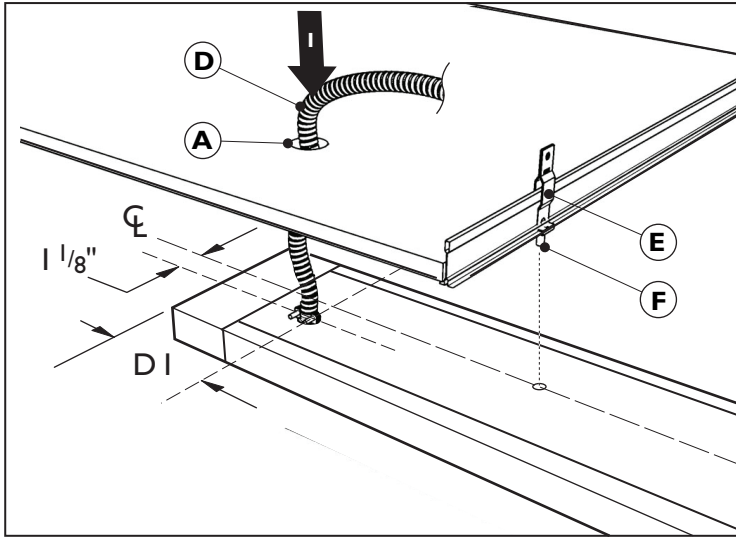

NOTE:

THE JUNCTION BOXES MUST BE SOLIDLY FIXED TO CEILING PRIOR TO FIXTURE INSTALLATION

FIXTURE ON T-BARS

- 1 Drill 1-1/2" hole (A) in the tile or drywall ceiling at D1" from end of fixture, 1-1/8" from centerline of fixture. (See chart A for dimension D1 values).
- 2 Remove louvers (B) and lamps (C) from fixture. Pass BX cable (D) through hole in ceiling and connect to solidly affixed junction box.
- 3 Hang fixture on t-bar clips (E) with 1/4 - 20 studs (F). Secure with nuts (G).
- 4 Replace louvers and lamps.

FIXTURE ON DRYWALL

- Dimensions and procedure same as above.
- T-bar clip (E) replaced with appropriate ceiling anchor (by others).
- Ensure 1/4 - 20 studs protrude from ceiling min. 3/8".

NOTE:
Available with
2 x T5 / T5HO
lamps ONLY

PART LIST

- A 1-1/2" hole
- B Louvers
- C Lamps
- D BX cable (by Axis)
- E T-bar clip (by Axis)
- F 1/4-20 stud
- G Nut

CHART A - CRITICAL DIMENSIONS

FIXTURE	D1	D2
Base	4"	53-3/8"
Sushi	3"	51-3/8"
L2	4-1/2"	54-3/8"
Cubic	4-1/2"	54-3/8"
101	3-1/8"	51-5/8"
202	3-1/8"	51-5/8"

CRITICAL DIMENSIONS

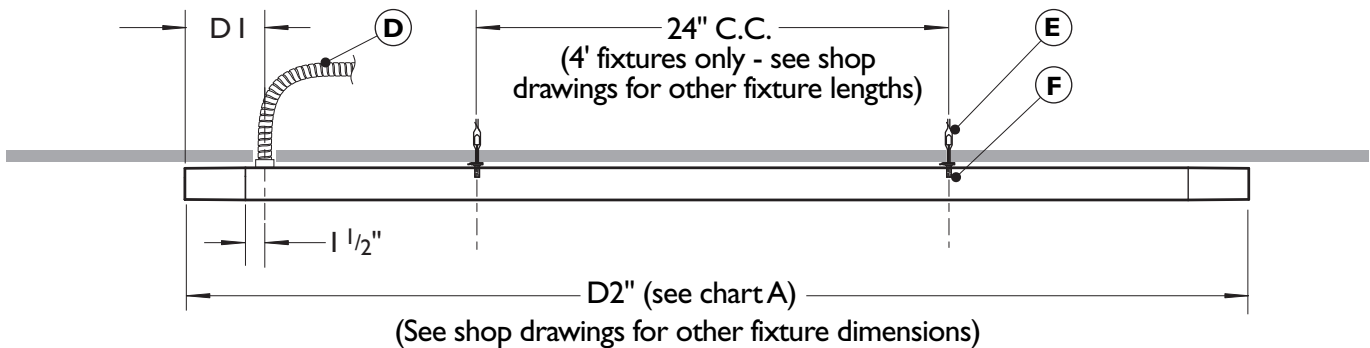

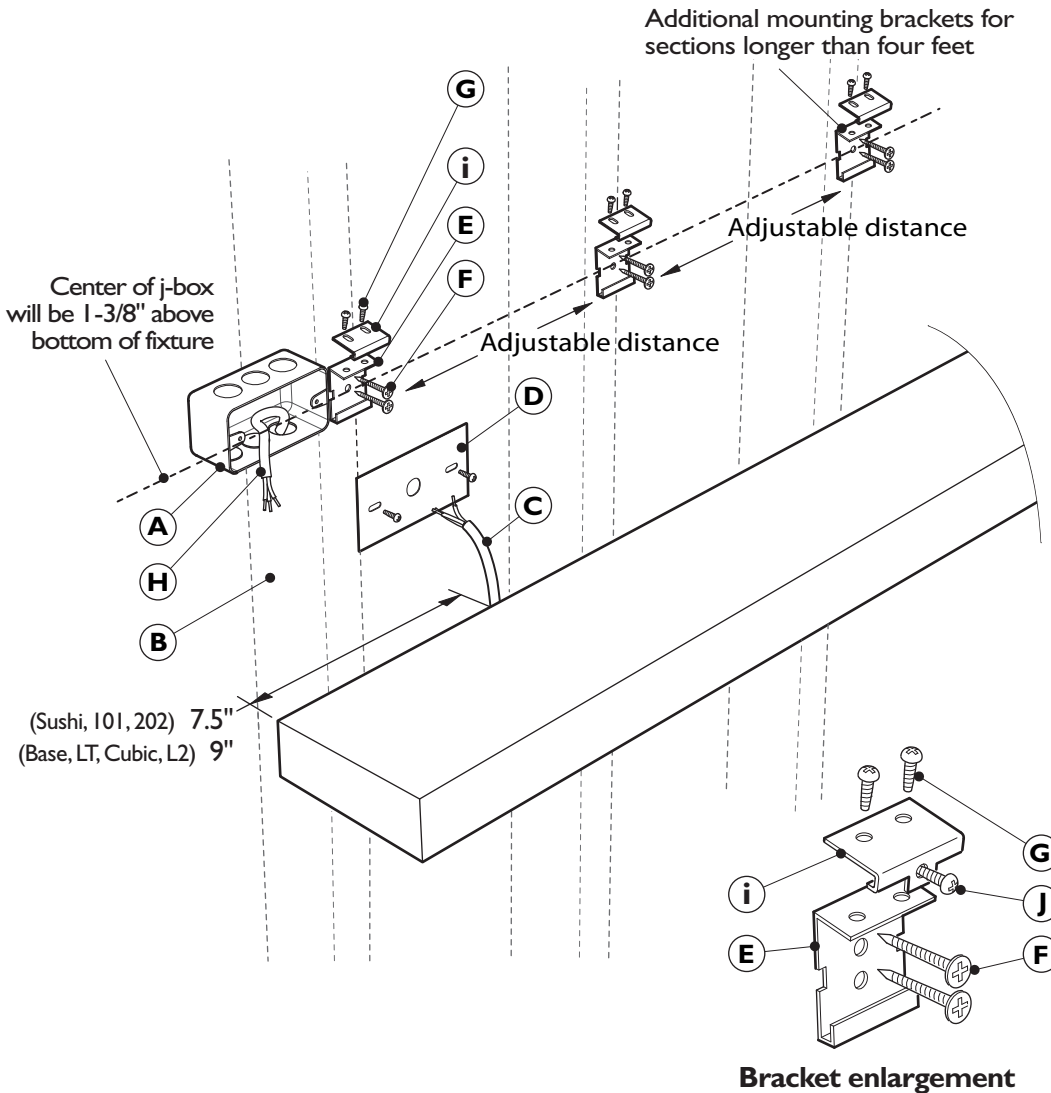

PART LIST

- A** 2"x4" j-box (by others)
- B** Wall stud
- C** Fixture power wire
- D** J-box cover (supplied)
- E** Wall brackets
- F** Screws (by others)
- G** Bracket screws
- H** J-box power wires
- i** Levelling bracket
- J** Adjustment screws

Step 5 : Placing fixture

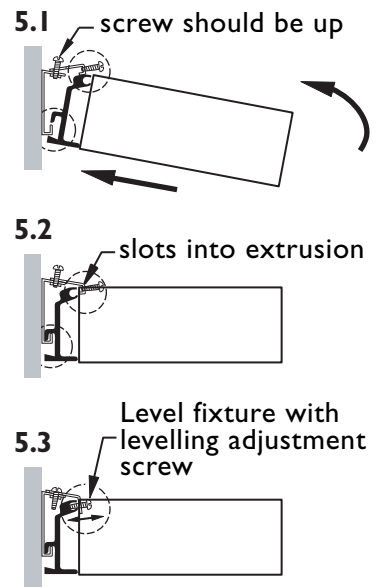

INSTALLATION OF WALL FIXTURES :

- 1 Determine fixture position :** Height should be min. 74" A.F.F. to bottom of fixture. Ensure at least 12" from ceiling to top of fixture. It is recommended to match height of suspended light fixtures if present.
- 2 Install junction box :** Attach a 2"x4" j-box (A) horizontally to left side of wall stud (B) which will be approx. 12" from the left end of fixture (see image). Center of j-box should be 1-3/8" above desired bottom height of fixture. Leave 8-10" of fixture power wire (C) exposed. Do not install j-box cover (D) yet.
- 3 Install Wall Brackets :** Install wall brackets (E) on wall studs (see above) using appropriate screws (F). Align notch on power side wall bracket with vertical center line of j-box (use of plumbline recommended). Loosen bracket screws (G).
- 4 Connect :** Place fixture on supports (e.g. step-ladder) near junction box height. Slide fixture power wire (C) through j-box cover (D). Splice fixture power wire and j-box power wires (H). Stuff excess wires in j-box, slide & screw j-box cover in place.
- 5 Placing fixture :** Lift fixture correctly onto brackets (see step 5 diagram) making sure levelling bracket (i) catches on fixture.
- 6 Level :** Hold fixture level and adjust levelling adjustment screws (J).

SYSTEM RUNS : Install each section separately on wall as per instructions above. Slide internal joining extrusions into the joining fixture and fasten the 2 horizontal nuts & bolts through the joining endplates. (See page i2.15 - Pendant Installation for diagram).